

Instruction Manual

Model SA11
Smart Adapter



(BG)

Всички улътвания за продукти от серията ATEX Ex се предлагат на английски език. Ако се нуждаете от улътвания за продукти от серията Ex на родния ви език, се свържете с най-близкия офис или представителство на фирма Yokogawa.

(CZ)

Všechny uživatelské příručky pro výrobky, na něž se vztahuje nevybušné schválení ATEX Ex, jsou dostupné v angličtině. Požadujete-li pokyny týkající se výrobků s nevybušným schválením ve vašem lokálním jazyku, kontaktujte prosím vaši nejbližší reprezentační kancelář Yokogawa.

(D)

Alle Betriebsanleitungen für ATEX Ex bezogene Produkte stehen in den Sprachen Englisch. Sollten Sie die Betriebsanleitungen für Ex-Produkte in Ihrer Landessprache benötigen, setzen Sie sich bitte mit Ihrem örtlichem Yokogawa-Vertreter in Verbindung.

(DK)

Alle brugervejledninger for produkter relateret til CE er tilgængelige på engelsk. Skulle De ønske yderligere oplysninger om håndtering af CE produkter på eget sprog, kan De rette henvendelse herom til den nærmeste Yokogawa afdeling eller forhandler.

(EST)

Kõik ATEX Ex toodete kasutamishendid on esitatud inglise keeles. Ex seadmete muukeelse dokumentatsiooni saamiseks pöörduge lähima lokagava (Yokogawa) kontori või esindaja poole.

(E)

Todos los manuales de instrucciones para los productos antiexplosivos de ATEX están disponibles en inglés. Si desea solicitar las instrucciones de estos artículos antiexplosivos en su idioma local, deberá ponerse en contacto con la oficina o el representante de Yokogawa más cercano.

(F)

Tous les manuels d'instruction des produits ATEX Ex sont disponibles en langue anglaise. Si vous nécessitez des instructions relatives aux produits Ex dans votre langue, veuillez bien contacter votre représentant Yokogawa le plus proche.

(GB)

All instruction manuals for ATEX Ex related products are available in English. Should you require Ex related instructions in your local language, you are to contact your nearest Yokogawa office or representative.

(GR)

Όλα τα εγχειρίδια λειτουργίας των προϊόντων με ATEX Ex διατίθενται στα Αγγλικά. Σε περίπτωση που χρειάζεστε οδηγίες σχετικά με Ex στην τοπική γλώσσα παρακαλούμε επικοινωνήστε με το πλησιέστερο γραφείο της Yokogawa ή ενός επίσημου αντιπροσώπου της.

(H)

Az ATEX Ex műszerek gépkönyveit angol nyelven adjuk ki. Amennyiben helyi nyelven kérik az Ex eszközök leírásait, kérjük keressék fel a legközelebbi Yokogawa irodát, vagy képviselőt.

(I)

Tutti i manuali operativi di prodotti ATEX contrassegnati con Ex sono disponibili in inglese. Se si desidera ricevere i manuali operativi di prodotti Ex in lingua locale, mettersi in contatto con l'ufficio Yokogawa più vicino o con un rappresentante.

(LV)

Visas ATEX Ex kategorijas izstrādājumu Lietošanas instrukcijas tiek piegādātas angļu valodās. Ja vēlaties saņemt Ex ierīšu dokumentāciju citā valodā, Jums ir jāsazinās ar firmas Jokogava (Yokogawa) tuvāko ofisu vai pārstāvi.

(LT)

Visos gaminiø ATEX Ex kategorijos Eksploatavimo instrukcijos teikiami anglø kalbomis. Norëdami gauti priestaisø Ex dokumentacijà kitomis kalbomis susisiekite su artimiausiu bendrovës Yokogawa biuru arba atstovu.

(M)

Il-manwali kollha ta' l-istruzzjonijiet għal prodotti marbuta ma' ATEX Ex huma disponibbli bl-Ingliż. Jekk tkun teħtiegħ struzzjonijiet marbuta ma' Ex fil-lingwa lokali tiegħek, għandek tikkuntattja lill-eqreb rappreżentant jew ufficiċju ta' Yokogawa.

(NL)

Alle handleidingen voor producten die te maken hebben met ATEX explosie-beveiliging (Ex) zijn verkrijgbaar in het Engels. Neem, indien u aanwijzingen op het gebied van explosiebeveiliging nodig hebt in uw eigen taal, contact op met de dichtstbijzijnde vestiging van Yokogawa of met een vertegenwoordiger.

(P)

Todos os manuais de instruções referentes aos produtos Ex da ATEX estão disponíveis em Inglês. Se necessitar de instruções na sua língua relacionadas com produtos Ex, deverá entrar em contacto com a delegação mais próxima ou com um representante da Yokogawa.

(PL)

Wszystkie instrukcje obsługi dla urządzeń w wykonaniu przeciwwybuchowym Ex, zgodnych z wymaganiami ATEX, dostępne są w języku angielskim. Jeżeli wymagana jest instrukcja obsługi w Państwa lokalnym języku, prosimy o kontakt z najbliższym biurem Yokogawy.

(RO)

Toate manualele de instructiuni pentru produsele ATEX Ex sunt in limba engleza. In cazul in care doriti instructiunile in limba locala, trebuie sa contactati cel mai apropiat birou sau reprezentant Yokogawa.

(S)

Alla instruktionsböcker för ATEX Ex (explosionssäkra) produkter är tillgängliga på engelska. Om Ni behöver instruktioner för dessa explosionssäkra produkter på annat språk, skall Ni kontakta närmaste Yokogawakontor eller representant.

(SF)

Kaikkien ATEX Ex-tyyppisten tuotteiden käyttöohjeet ovat saatavilla englannin-. Mikäli tarvitsette Ex-tyyppisten tuotteiden ohjeita omalla paikallisella kielellänne, ottakaa yhteyttä lähimpään Yokogawa-toimistoon tai -edustajaan.

(SK)

Všetky návody na obsluhu pre prístroje s ATEX Ex sú k dispozícii v jazyku anglickom. V prípade potreby návodu pre Ex-prístroje vo Vašom národnom jazyku, skontaktujte prosím miestnu kanceláriu firmy Yokogawa.

(SLO)

Vsi predpisi in navodila za AEX Ex sorodni pridelki so pri roki v angliščini. Èe so Ex sorodna navodila potrebna v vašem tukejnem jeziku, kontaktirajte vaš najbliži Yokogawa office ili predstavnika.

(TR)

ATEX Ex ile ilgili tüm ürünlerin kullanım kılavuzları İngilizce olarak mevcuttur. Ex ile ilgili talimatlara yerel dilinizde ihtiyaç duymanız hâlinde, size en yakın Yokogawa ofisi veya temsilcisiyle iletişime geçmeniz gerekmektedir.

Introduction

Thank you for purchasing the SA11 Smart Adapter. Please read the following respective documents before installing and using the SA11. The SA11 Smart Adapter only works with Yokogawa sensors equipped with an ID-chip. If sensors without ID-chip are connected, all calculated output data of the SA11 will be disabled.

When the FLXA402 or UM33A-S00 is used as HOST of the SA11 slave device, please refer to the User's Manual IM 12A01F01-02 or IM 05P09D21-01EN too.

For the general specifications of the SA11 please refer to the GS 12A06S01-00EN-(P).

The related documents are as follows.

General Specifications

Contents	Document Number	Note
SA11 Smart Adapter	GS 12A06S01-00EN-P	Available for download
FLXA402 4-wire Analyzer	GS 12A01F01-01EN	
UM33A-S00 Digital Indicator	GS 05P03D21-01EN	
BA11 Active Junction Box	GS 12B06W03-01E-P	
Fieldmate	GS 01R01A01-01E	
IB100	GS 12B06J09-01E-P	
WU10/WE10 VP- and Ext. cable	GS 12B06W02-02E-P	
WU11 Interconnection cable	GS 12B06W02-03E-P	

User's Manual

Contents	Document Number	Note
SA11 Smart Adapter Start-up Manual	IM 12A06S01-01EN-P	Attached to the product
SA11 Smart Adapter User's Manual (English version)	IM 12A06S01-00EN-P	Available for download
SA11 Smart Adapter User's Manual (Japanese version)	IM 12A06S01-00JA-P	Available for download
FLXA402 4-wire Analyzer User's Manual	IM 12A01F01-02	Available for download
UM33A-S00 Digital Indicator	IM 05P09D21-11EN	Attached to the product
BA11 Active Junction Box	IM 12B06W03-01EN-P	Attached to the product
WU11 Interconnection cable	IM 12B06W02-03EN-P	Attached to the product
WE10	IM 12B06W02-02EN-P	Attached to the product
IB100 Interface Box	IM 12B06J09-01EN-P	Available for download
Fieldmate	IM 01R01A01-01E	Available for download
SA11 Smart Adapter Modbus Communication	TI 12A06S01-00EN-P	Available for download
C.E. handbook SA11 Smart Adapter	CE 12A06S01-00EN-P	Available for download

Note: The "E" or "EN" in the document number is the language code for English version, the "JA" indicates the Japanese version.

Downloads can be done from: <https://www.yokogawa.com/solutions/products-platforms/process-analyzers/liquidanalyzers/#Downloads>. You can use the QR-code for quick-access.

IM12A06S01-00EN-P



Notes on Handling User's Manuals

- Please hand over the user's manuals to your end users so that they can keep the user's manuals on hand for convenient reference.
- Please read the information thoroughly before using the product.
- The purpose of these user's manuals is not to warrant that the product is well suited to any purpose but rather to describe the functional details of the product.
- No part of the user's manuals may be transferred or reproduced without prior written consent from YOKOGAWA.
- YOKOGAWA reserves the right to make improvements in the user's manuals and product at any time, without notice or obligation.
- If you have any questions, or you find mistakes or omissions in the user's manuals, please contact our sales representative or your local distributor.

Drawing Conventions

Some drawings may be partially emphasized, simplified, or omitted, for the convenience of description. Some screen images depicted in the user's manual may have different display positions or character types (e.g., the upper / lower case). Also note that some of the images contained in this user's manual are display examples.

Composition of this User's Manual

Contents	pH/ORP	Specific Conductivity
Introduction and general description	Section 1	
Wiring and installation	Section 2	
Operation	Section 3	Section 6
Commissioning	Section 4	Section 7
Calibration	Section 5	Section 8
Maintenance	Section 9	
Troubleshooting	Section 10	
Appendices	Section 11	

Safety Precautions

Safety, Protection, and Modification of the Product

- In order to protect the system controlled by the product and the product itself and ensure safe operation, observe the safety precautions described in this user's manual. We assume no liability for safety if users fail to observe these instructions when operating the product.
- If this instrument is used in a manner not specified in this user's manual, the protection provided by this instrument may be impaired.
- If any protection or safety circuit is required for the system controlled by the product or for the product itself, prepares it separately.
- Be sure to use the spare parts approved by Yokogawa Process Analyzers (simply referred to as YOKOGAWA) when replacing parts or consumables.
- Modification of the product is strictly prohibited.
- The following safety symbols are used on the product as well as in this manual.



This symbol indicates that an operator must follow the instructions laid out in this manual to avoid the risks, for the human body, of injury, electric shock, or fatalities. The manual describes what special care the operator must take to avoid such risks.



This symbol indicates that the operator must refer to the instructions in this manual to prevent the instrument (hardware) or software from being damaged, or a system failure from occurring.

CAUTION

This symbol gives information essential for understanding the operations and functions.

NOTE

This symbol indicates information that complements the present topic.



This symbol indicates Protective Ground Terminal.



This symbol indicates Function Ground Terminal. Do not use this terminal as the protective ground terminal.

Warning and Disclaimer

The product is provided on an "as is" basis. YOKOGAWA shall have neither liability nor responsibility to any person or entity with respect to any direct or indirect loss or damage arising from using the product or any defect of the product that YOKOGAWA cannot predict in advance.

SA11

The SA11 should only be used with equipment that meets the relevant IEC, American, Canadian, and Japanese standards. YOKOGAWA accepts no responsibility for the misuse of this unit.



The Instrument is packed carefully with shock absorbing materials, nevertheless, the instrument may be damaged or broken if subjected to strong shock, such as if the instrument is dropped. Handle with care.



The SA11 contains devices that can be damaged by electrostatic discharge. When servicing this equipment, please observe proper procedures to prevent such damage



Do not use an abrasive or organic solvent in cleaning the instrument.



This instrument is an EN61326-1 Class A product, and it is designed for use in the industrial environment. Please use this instrument in the industrial environment only.

Special conditions of use

Potential electrostatic charging hazard – When the equipment is used in hazardous locations, avoid any actions which generate electrostatic discharge, such as rubbing with a dry cloth.



Risque potentiel de charge électrostatique - Lorsque l'équipement est utilisé dans des zones dangereuses, évitez toute action générant une décharge électrostatique, comme un frottement avec un chiffon sec.



The Input Port connections incorporate an earthed conductor. Care shall be taken to prevent ignition-capable earth currents resulting from differing earth potentials between the SA11 and Host. Refer to section 2-3 for instructions concerning earthing and isolation of the SA11.



Les connexions du port d'entrée comportent un conducteur mis à la terre. Des précautions doivent être prises pour éviter les courants de terre capables d'allumage résultant de potentiels de terre différents entre le SA11 et l'hôte. Reportez-vous à la section 2-3 pour les instructions concernant la mise à la terre et l'isolement du SA11.

Ambient temperature conditions depend on the temperature class:

T6: $-30^{\circ}\text{C} \leq T_a \leq +40^{\circ}\text{C}$

T5: $-30^{\circ}\text{C} \leq T_a \leq +60^{\circ}\text{C}$

T4: $-30^{\circ}\text{C} \leq T_a \leq +80^{\circ}\text{C}$

T3: $-30^{\circ}\text{C} \leq T_a \leq +80^{\circ}\text{C}$

Product Disposal

The instrument should be disposed of in accordance with local and national legislation/regulations.

Warranty and service

Yokogawa products and parts are guaranteed free from defects in workmanship and material under normal use and service for a period of (typically) 12 months from the date of shipment from the manufacturer.

Individual sales organizations can deviate from the typical warranty period, and the conditions of sale relating to the original purchase order should be consulted. Damage caused by wear and tear, inadequate maintenance, corrosion, or by the effects of chemical processes are excluded from this warranty coverage.

In the event of warranty claim, the defective goods should be sent (freight paid) to the service department of the relevant sales organization for replacement (at Yokogawa discretion).

The following information must be included in the letter accompanying the returned goods:

- Part number, model code and serial number
- Original purchase order and date
- Length of time in service and a description of the process
- Description of the fault, and the circumstances of failure
- Process/environmental conditions that may be related to the failure of the device.
- A statement whether warranty or non-warranty service is requested
- Complete shipping and billing instructions for return of material, plus the name and phone number of a contact person who can be reached for further information.

Returned goods that have been in contact with process fluids must be decontaminated /disinfected before shipment. Goods should carry a certificate to this effect, for the health and safety of our employees.

Material safety data sheets should also be included for all components of the processes to which the equipment has been exposed.

Copyright and Trademark Notices

The online manual is protected by the PDF security from modification, however, it can be output via a printer. Printing out the online manual is only allowed for using the product. When using the printed information of the online manual, check if the version is the most recent one by referring to the version attached to the product. No part of the online manual may be transferred, sold, distributed (including delivery via a commercial PC network or the like), or registered or recorded on video tapes.

FLEXA, FLXA, SENCOM and FieldMate are trademarks or registered trademarks of Yokogawa Electric Corporation.

Adobe, Acrobat and Acrobat Reader are either registered trademarks or trademarks of Adobe Systems Incorporated in the United States and/or other countries.

All other company and product names mentioned in this user's manual are trademarks or registered trademarks of their respective companies.

We do not use TM or ® mark to indicate those trademarks or registered trademarks in this user's manual.

SA11 fonts

(c) Copyright 2000-2001 /efont/ The Electronic Font Open Laboratory. All rights reserved.

Redistribution and use in source and binary forms, with or without modification, are permitted provided that the following conditions are met:

1. Redistributions of source code must retain the above copyright notice, this list of conditions and the following disclaimer.
2. Redistributions in binary form must reproduce the above copyright notice, this list of conditions and the following disclaimer in the documentation and/or other materials provided with the distribution.
3. Neither the name of the team nor the names of its contributors may be used to endorse or promote products derived from this font without specific prior written permission.

THIS FONT IS PROVIDED BY THE TEAM AND CONTRIBUTORS "AS IS" AND ANY EXPRESS OR IMPLIED WARRANTIES, INCLUDING, BUT NOT LIMITED TO, THE IMPLIED WARRANTIES OF MERCHANTABILITY AND FITNESS FOR A PARTICULAR PURPOSE ARE DISCLAIMED. IN NO EVENT SHALL THE TEAM OR CONTRIBUTORS BE LIABLE FOR ANY DIRECT, INDIRECT, INCIDENTAL, SPECIAL, EXEMPLARY, OR CONSEQUENTIAL DAMAGES (INCLUDING, BUT NOT LIMITED TO, PROCUREMENT OF SUBSTITUTE GOODS OR SERVICES; LOSS OF USE, DATA, OR PROFITS; OR BUSINESS INTERRUPTION) HOWEVER CAUSED AND ON ANY THEORY OF LIABILITY, WHETHER IN CONTRACT, STRICT LIABILITY, OR TORT (INCLUDING NEGLIGENCE OR OTHERWISE) ARISING IN ANY WAY OUT OF THE USE OF THIS FONT, EVEN IF ADVISED OF THE POSSIBILITY OF SUCH DAMAGE.

CE marking products**Authorized Representative in EEA**

The Authorized Representative for this product in EEA is Yokogawa Europe B.V., Euroweg 2, 3825 HD Amersfoort, The Netherlands.

Identification Tag

This manual and the identification tag attached on a packing box are essential parts of the product. Keep them together in a safe place for future reference.

Users

This product is designed to be used by a person with specialized knowledge.

Table of Contents

Introduction.....	4
General Specifications.....	4
User's Manual.....	4
Safety Precautions.....	6
Warning and Disclaimer.....	6
SA11.....	7
Special conditions of use.....	7
Product Disposal.....	8
Warranty and service.....	8
Copyright and Trademark Notices.....	8
CE marking products.....	9
1 INTRODUCTION AND GENERAL DESCRIPTION	13
1.1. Instrument check.....	13
1.2. Checking the accessories	14
1.3. Regulatory Compliance.....	14
1.4. Model & Suffix Codes.....	20
1.5. Spare part list.....	20
2 WIRING AND INSTALLATION.....	21
2.1 Installation site	21
2.2 Connecting to the sensor	21
2.2.1 Direct mounting.....	21
2.2.2 Cable mounting.....	22
2.3 Wiring to the HOST system	22
2.3.1 Wired connection	22
2.3.2 Connection in daisy chain concept.....	22
2.3.3 Wireless connection	23
2.3.4 Control drawings	25
3 OPERATION OF pH/ORP	28
3.1 SA11 quick setup	28
3.2 Measurement setup.....	28
3.2.1 Parameter setting.....	28
3.2.2 Temperature setting	28
3.3 pH/ORP zero, slope and impedance	28
3.3.1 Zero	28
3.3.2 Slope	28
3.3.3 Impedance	29
3.4 Diagnostics	29
3.4.1 Liquid Earth (LE) detection	29
3.4.2 Device state.....	29
3.4.3 Calibration due	29
IM12A06S01-00EN-P	

3.4.4 Last calibrated.....	11
3.4.5 Predictive maintenance.....	30
3.4.6 Sensor wellness.....	30
3.4.7 Sensor status.....	31
3.5 Output setup.....	32
3.6 Calibration and Commissioning.....	32
4 COMMISSIONING OF pH/ORP.....	33
4.1 Measurement setup.....	33
4.1.1 Measurement select.....	33
4.1.2 Temperature settings.....	33
4.1.3 Temperature compensation.....	33
4.1.4 Process compensation.....	34
4.1.5 pH settings.....	34
4.1.6 ORP settings.....	35
4.1.7 rH settings.....	35
4.1.8 Impedance settings.....	35
4.1.9 Unit conversion.....	35
4.1.10 Calibration settings for pH/ORP1/ORP2.....	35
4.2 Communication setup.....	36
4.3 Error configuration.....	36
4.4 Logbook configuration.....	39
5 CALIBRATION OF pH/ORP.....	40
5.1 Temperature calibration.....	40
5.2 pH calibration.....	40
5.2.1 Manual calibration.....	40
5.2.2 Automatic calibration.....	41
5.2.3 Sample calibration.....	41
5.2.4 Fully Automatic calibration.....	42
5.3 ORP/rH calibration.....	42
6 OPERATION OF SC (Specific Conductivity).....	43
6.1 SA11 quick setup.....	43
6.2 Measurement setup.....	43
6.2.1 Parameter setting.....	43
6.2.2 Temperature setting.....	43
6.3 Cell constant & polarization.....	43
6.3.1 Cell constant.....	43
6.3.2 Polarization.....	43
6.4 Diagnostics.....	43
6.4.1 Device state.....	43
6.4.2 Calibration due.....	44
6.4.3 Last calibrated.....	44
6.4.4 Predictive maintenance.....	44
6.4.5 Sensor wellness.....	44
6.4.6 Sensor status.....	45

6.5 Output setup	45
6.6 Calibration and Commissioning	45
7 COMMISSIONING OF SC (Specific Conductivity).....	46
7.1 Measurement setup	46
7.1.1 Measurement select.....	46
7.1.2 Temperature settings.....	46
7.1.3 Temperature compensation.....	46
7.1.4 Process compensation.....	46
7.1.5 Concentration	47
7.1.6 USP23	47
7.1.7 SC settings.....	47
7.1.8 Unit conversion.....	48
7.1.9 Calibration settings for Conductivity/Resistivity.....	48
7.2 Communication setup.....	48
7.3 Error configuration.....	49
7.4 Logbook configuration	50
8 CALIBRATION OF SC (Specific Conductivity)	51
8.1 Temperature calibration	51
8.2 Cell constant calibration	51
8.2.1 Cell constant (manual)	51
8.2.2 Cell constant (automatic).....	51
8.2.3 Sample	52
8.3 Temperature coefficient (TC).....	52
9 MAINTENANCE	53
9.1 Periodic maintenance SA11.....	53
9.2 Periodic maintenance of sensors	53
10 TROUBLESHOOTING.....	54
10.1 Installation of SA11	54
10.2 Setting of the SA11	54
10.3 Sensor	54
10.4 Application.....	54
10.5 Functional Check	54
11 APPENDICES	55
11.1 Appendix 1: Factory defaults & setting limits pH.....	55
11.2 Appendix 2: Buffer tables and matrix compensation pH.....	57
11.3 Appendix 3: Logbook pH	59
11.4 Appendix 4: Factory defaults & setting limits SC.....	60
11.5 Appendix 5: Matrix tables and buffer solutions SC.....	61
11.6 Appendix 6: USP <645>	65
11.7 Appendix 7: Logbook SC.....	66

1 INTRODUCTION AND GENERAL DESCRIPTION

This manual describes how to use SA11 with Yokogawa's HOST systems and sensors. Please read carefully this manual and the instruction manual of the relevant HOST system and sensor before using this SA11 slave device.

The model SA11 Smart Adapter can perform 2 kind of measurements, each measurement having its own specific SA11 model of which the pH parameter is divided into a model for conventional pH sensors and a model for differential pH sensors:

- 1a. pH/ORP (oxidation-reduction potential) for conventional sensors, model SA11-P1;
- 1b. pH/ORP (oxidation-reduction potential) for differential sensors, model SA11-P2;
2. Contact Conductivity (SC), model SA11-C1.

1.1. Instrument check

Upon delivery, unpack the device carefully and inspect it to ensure that it was not damaged during shipment. If damage is found, retain the original packing materials (including the outer box) and then immediately notify the carrier and the relevant Yokogawa sales office.

• Checking the model and suffix code

Make sure the model and suffix code on the metallized label affixed to the device housing are in line with the order. Refer to Section 1.4.

Note: Be sure to apply correct power to the device, as detailed on the label.



CAUTION

The device is packed carefully in a shock absorbing box, nevertheless, the device may be damaged or broken if subjected to strong shock, such as if the box is dropped. Handle with care.

• Checking the serial number

The Serial Number is defined by nine (9) alphanumeric characters as follows:

$X_1X_2Y_3M_4N_5N_6N_7N_8N_9$	e.g. N3U100021
X_1X_2 :	Production Site
Y_3M_4 :	Year/Month code
$N_5N_6N_7N_8N_9$:	Tracking number

Table 1.1: Production year code

Year	Year code	Year	Year code	Year	Year code	Year	Year code
2010	K	2015	R	2020	W	2025	2
2011	L	2016	S	2021	X	2026	3
2012	M	2017	T	2022	Y	2027	4
2013	N	2018	U	2023	Z	2028	5
2014	P	2019	V	2024	1	2029	6

Table 1.2: Production month code

Month	Month code	Month	Month code	Month	Month code
January	1	May	5	September	9
February	2	June	6	October	A
March	3	July	7	November	B
April	4	August	8	December	C

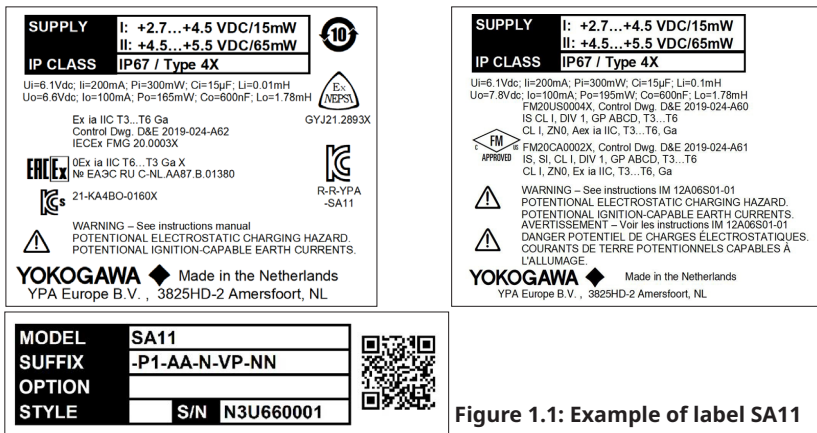

Figure 1.1: Example of label SA11

1.2. Checking the accessories

Make sure that besides the SA11 device the accessories in Table 1.3 are included. Options are available only if ordered.

Table 1.3: Accessories

Product Name	Quantity	Remark
SA11 Smart Adapter dust caps	2 pcs/device	To prevent dust inside the connectors
Option: Universal mounting set	1 set	Option code /UM*
Startup Manual	1 copy	Quick startup description
QIS/QIC	1 copy	Test certificate

* Option /UM contains Pipe and Wall mounting hardware

Note: Be sure to remove the dust caps before using the device.

1.3. Regulatory Compliance

Item	Description
Installation	Overvoltage Category I Pollution Degree 2 Altitude 2000 m or less
EMC	EU Directive 2014/30/EU (European Union) Electromagnetic Compatibility Regulations 2016 (UK) RCM (Australia/New Zealand) KC (Korea), Registration no. R-R-YPA-SA11 GB 30439 (China)
EU	EU Declaration of Conformity Declaration Of Conformities, see page 17-18
China	Protection of Environment RoHS China, see page 19

Item	Description, Approval, Certification
ATEX (EU)	ATEX approval: FM 20ATEX0001X CE 0344 Ex II 1 G Ex ia IIC T3...T6 Ga Control Drawing: D&E 2019-024-A62 Applied standards: <ul style="list-style-type: none"> • EN IEC 60079-0 • EN 60079-11
IECEX	IECEX approval: IECEX FMG 20.0003X Ex ia IIC T3...T6 Ga Applied standards: <ul style="list-style-type: none"> • IEC 60079-0 • IEC 60079-11
FM (Canada)	FM approval Canada: FM20CA0002X IS SI CL I, DIV 1, GP ABCD, T3...T6 CL I, ZN 0, Ex ia IIC, T3...T6 Ga Control Drawing: D&E 2019-024-A61 Applied standards: <ul style="list-style-type: none"> • CAN/CSA-C22.2 No. 60079-0 • CAN/CSA-C22.2 No. 60079-11 • CAN/CSA-C22.2 No. 61010-1
FM (United States)	FM approval United States: FM20US0004X IS CL I, DIV 1, GP ABCD, T3...T6 CL I, ZN 0, AEx ia IIC, T3...T6 Ga Control Drawing: D&E 2019-024-A60 Applied standards: <ul style="list-style-type: none"> • FM Class 3600 • FM Class 3610 • FM Class 3810 • ANSI/ISA 60079-0 • ANSI/ISA 60079-11 • ANSI/ISA 61010-1
NEPSI (China)	NEPSI approval: GYJ21.2893X Ex ia IIC T3...T6 Ga Applied standards: <ul style="list-style-type: none"> • GB 3836.1 • GB 3836.4 • GB 3836.20

Item	Description, Approval, Certification
PESO (India)	PESO approval: PESO approval is based on ATEX approval FM 20ATEX0001X, issue 1 – 07.04.2020 Equipment reference numbers: P501815/1 Applied standards: <ul style="list-style-type: none"> • EN IEC 60079-0 • EN 60079-11
TS (Taiwan)	TS approval: TS Safety Label is based on IECEx approval IECEx FMG 20.0003X Identification Number: TD04000C Applied standards: <ul style="list-style-type: none"> • IEC 60079-0 • IEC 60079-11
KCs (Korea)	Korea Ex certificates: Korea Ex certificate is based on IECEx approval IECEx FMG 20.0003X, issue 0 and applicable for the following models: SA11-C1-CG-*-VS-**/*: 21-KA4BO-0159X SA11-P1-CG-*-VS-**/*: 21-KA4BO-0160X SA11-P2-CG-*-VS-**/*: 21-KA4BO-0160X Applied standards: <ul style="list-style-type: none"> • IEC 60079-0 • IEC 60079-11
EACEx (Russia)	EAC Ex certificate: EAЭC RU C-NL.AA87.B.01380 0Ex ia IIC T6...T3 Ga X Applied standards: <ul style="list-style-type: none"> • GOST 31610.0 (IEC 60079-0) • GOST 31610.11 (IEC 60079-11) • GOST IEC 60079-14

Declaration of Conformity for SA11



YOKOGAWA ◆

EU DECLARATION OF CONFORMITY

We: **Yokogawa Process Analyzers Europe B.V.**
Euroweg 2, 3825 HD Amersfoort
The Netherlands

Herewith declare under our sole responsibility that the product, model: **SA11** further specified with model suffix- and option codes: **As listed in Annex-1 in this document**, is manufactured in accordance with the requirements for CE-marking of products as stated in EC Decision:

768/2008/EC on a common framework for the marketing of products

by applying the following standards:

EN-ISO 9001:2015 Quality management systems - Requirements

Subject product (type AA and CB), is:

- Produced according to appropriate quality control procedures.
- In compliance with the essential requirements of the specific product legislation:

- **EMC** **Directive 2014/30/EU**

by applying the following standards:

EN 61326-1:2013 Electrical equipment for measurement, control and laboratory use
 – EMC requirements – Part 1: General requirements.
 Emission: Class A, control and laboratory use.
 Immunity: For use in industrial locations.

EN 55011:2016 Industrial, scientific and medical equipment – Radio-frequency disturbance characteristics - Limits and methods of measurement.
/A1:2017 Emission: Radiated emission up to 1 GHz (SAC).

- **LVD** **Directive 2014/35/EU**

by applying the following standards:

EN 61010-1:2010 Safety requirements for electrical equipment for measurement, control and laboratory use – Part 1: General requirements.

EN 61010-2-030:2010 Safety requirements for electrical equipment for measurement, control, and laboratory use - Part 2-030: Particular requirements for testing and measuring circuits.

EN 60529:1992 Degrees of protection provided by enclosures (IP Code).

/A1:2000; /A2:2013

- **RoHS** **Directive 2011/65/EU**

Commission Delegated Directive (EU) 2015/863 amending Annex II to Directive 2011/65/EU as regards the list of restricted substances, by applying the following standards:

EN-IEC 63000: 2018 Technical documentation for the assessment of electrical and electronic products with respect to the restriction of hazardous substances.

Furthermore, subject product (type CB), is:

- In compliance with the essential requirements of the specific product legislation:

- **Potentially explosive atmospheres** **Directive 2014/34/EU (ATEX)**

by applying the following standards:

EN IEC 60079-0:2018 Explosive atmospheres – Part 0: Equipment general requirements

EN 60079-11:2012 Explosive atmospheres – Part 11: Equipment protection by intrinsic safety "i"
/IS 01:2014

The provisions fulfilled are: Ⓢ II 1 G Ex ia IIC T3...T6 Ga

Number of the EU-type Examination Certificate: **FM20ATEX0001X**

Identification number of the notified body that issued the EU Quality Assurance Notification: 0344

Address of the notified body: Meander 1051, 6825 MJ Arnhem, The Netherlands

The CE-mark has been affixed on the product in 2018 for the first time.

If applicable, the product is checked against the latest official released revision of the standards mentioned above. Differences do not affect the certified product identified on this declaration.

Amersfoort – March 21, 2025

M. de Bruijn
General Manager
Yokogawa Process Analyzers Europe B.V.

Annex-1: SA11 Model code

Model	Suffix code	Option code	Description
SA11			SENCOM Smart Adapter
Measuring Parameter	-C1 -P1 -P2		Contact Conductivity (SC) pH/ORP, conventional pH/ORP, differential
Type	-AA -CB -CD		General purpose IS for ATEX, IECEx IS for FM, CSA
Region (Note)	-N		Not specified
Connection type	-VS		Variopin connector
Style (Note)	-NN		Always -NN
Option (Note)		/UM	Pipe and wall mounting hardware

Note: Region code, Style code and Option code is not affecting intrinsic safety (IS)

Further specifications can be found in General Specification Sheet GS 12A06S01-00EN-(P).

Protection of environment Certificate for SA11

Instruction Manual

适配器 : SA11

Protection of Environment (Use in China)

This manual is valid only in China.
中華人民共和国国内でのみ有効です。

产品中有害物质的名称及含量

部件名称	有害物质									
	铅 (Pb)	汞 (Hg)	镉 (Cd)	六价铬 (Cr (VI))	多溴联苯 (PBB)	多溴二苯醚 (PBDE)	邻苯二甲酸二正丁酯 (DBP)	邻苯二甲酸二异丁酯 (DIBP)	邻苯二甲酸丁基酯 (BBP)	邻苯二甲酸二(2-乙基)己酯 (DEHP)
适配器	×	○	○	○	○	○	○	○	○	○

- 注 1: ○: 表示该有害物质在该部件所有均质材料中的含量均不超过电器电子产品有害物质限制使用国家标准要求。
×: 表示该有害物质至少在该部件的某一均质材料中含量超出电器电子产品有害物质限制使用国家标准要求。
- 注 2: 以上未列出的部件, 表明其有害物质含量均不超过电器电子产品有害物质限制使用国家标准要求。

环保使用期限: 这个标志是基于 SJ/T11364, 在中国 (不包括台湾, 香港, 澳门) 販售的电器电子产品所适用的环保使用期限。
只要遵守产品上关于安全及使用上的注意事项, 从制造之日起计算在该年限内, 不会发生制品内的有害物质外泄, 突然变异, 对环境或人体以及财产产生重大影响的情况。



(注) 该年限是《环境保护使用期限》, 不是产品的质保期限。
另外, 关于替换部件的推荐替换周期, 请阅读使用说明书。

Production date

关于生产日期

生产日期在产品铭牌上9位数的序列号中, 用以下形式表示生产日期。

从左数第3位数: 生产年份

R:2015, S:2016, T:2017, U:2018, V:2019, W:2020, X:2021, Y:2022, Z:2023,

1:2024, 2:2025, 3:2026, 4:2027, ...

从左数第4位数: 生产月份

1: 1月, 2: 2月, 3: 3月, ..., 9: 9月, A: 10月, B: 11月, C: 12月

(示例) N3S700001: 2016年7月

Subject to change without notice

YOKOGAWA ◆
YPA Europe

Copyright©2016 YPA Europe B.V
Euroweg 2, 3825 HD, Amersfoort The Netherlands

IM12A06A03-00EN-P
10th edition December, 2025
Printed in The Netherlands

1.4. Model & Suffix Codes

Model	Suffix code	Option	Description
SA11			SENCOM Smart Adapter
Measuring Parameter	- P1 - P2 - C1		pH/ORP, conventional pH/ORP, differential Specific Conductivity
Type	- AA - CB - CD		General purpose IS for ATEX, IECEX IS for FM-US, FM-Canada
Region	-N		Not specified
Connection type	- VS		Variopin connector for SENCOM ID-chip in sensor
Style	-NN		Always -NN
Option		/UM	Pipe and wall mounting hardware

1.5. Spare part list

Order no.	Product Name	Quantity	Remark
K1548PQ	Universal mounting set	1 set	Option /UM
K1548GF	O-ring set (5 pieces)	1 set	

*Option /UM contains Pipe and Wall mounting hardware

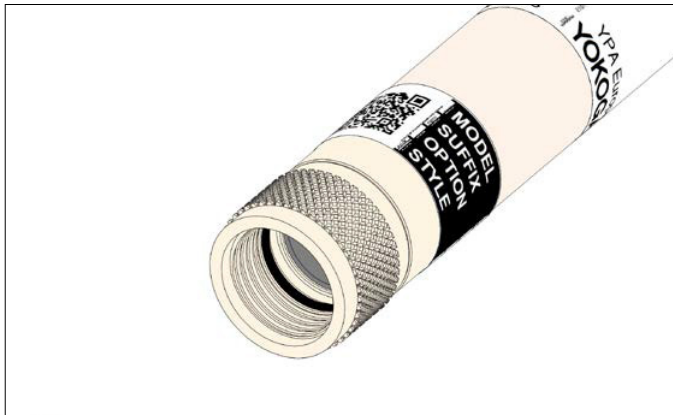

Figure 1.2: Positioning of O-ring

2 WIRING AND INSTALLATION

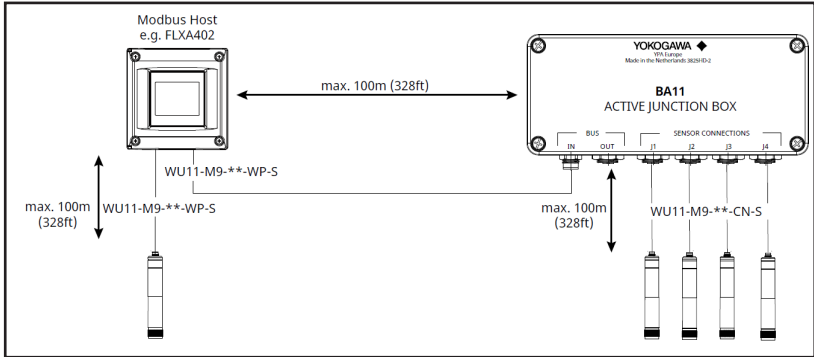

Figure 2.1: Installation diagram SA11

Please check the Control Drawings in Section 2.3.4 for wiring and installation in a hazardous area.

2.1 Installation site

The SA11 is weatherproof and can be installed both inside and outside. Select an installation site that meets the following conditions:

- Mechanical vibrations and shocks are negligible
- No relay switch and power switch are installed close to the device
- There is space mounting the device to the Yokogawa- sensor & Yokogawa HOST system
- Not exposed to direct sunlight or severe weather conditions
- Maintenance is possible
- No corrosive atmosphere
- Water Protection: IP67, NEMA Type 4X

2.2 Connecting to the sensor

2.2.1 Direct mounting

The SA11 can be installed directly on top of the YOKOGAWA labelled sensor by means of the Variopin connection system. In this case the temperature limit of the device is determined by the process temperature, limited from -30 up to +100°C / -22 up to +212°F for power supply +2.7 to +4.5VDC, -30 up to +125°C / -22 up to +257°F for power supply +4.5 to +5.5VDC.

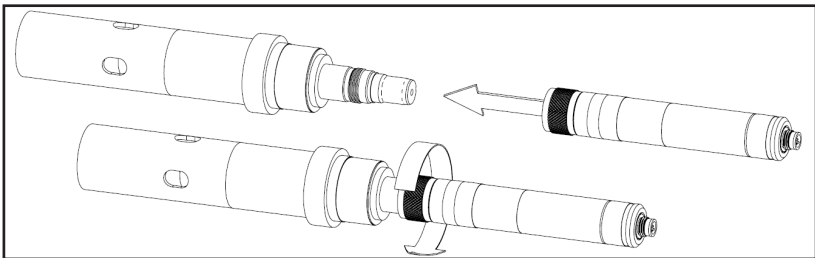

Figure 2.2: Example of direct mounting of SA11 to sensor

CAUTION

Place the Variopin connectors securely to guarantee IP67.

2.2.2 Cable mounting

When there is less room to install the SA11 on top of the YOKOGAWA labelled sensor or when the process conditions are higher than +100°C (for power supply +2.7 to +4.5VDC) or +125°C (for power supply +4.5 to +5.5VDC), an alternative mounting method is to install the SA11 using the optional wall/pipe mounting hardware. The SA11 in this case is connected to the sensor using the dedicated extension cable model WE10 with a fixed length of 3 meter. The ambient temperature limit of the device has to be within -30 to +55°C.

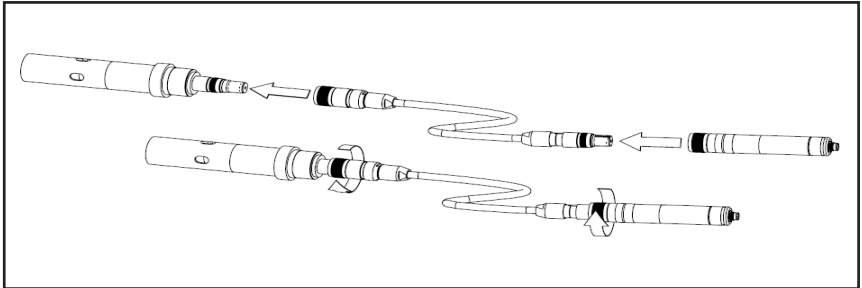

Figure 2.3: Example of cable mounting of SA11 to sensor

CAUTION

Place the Variopin connectors securely to guarantee IP67.

Note: Use the correct Variopin cable. For correct measurement without loss of specification the SA11-P1 must be used with WE10-H-D-003-V1, all other types must be used with WE10-H-D-003-V2.

2.3 Wiring to the HOST system**2.3.1 Wired connection**

The YOKOGAWA HOST system is connected to the SA11 using the WU11 type S interconnection cable with at one end wired terminals and on the other end a M9 connector. This cable is specified for reliable transfer of digital signals, and especially designed to be installed in a heavy industrial environment. The double shielded cable will protect the connected devices for interference from high voltages and currents which are present on other cables. The cable is specified to be used in IP67 applications, allowing it to be submerged as a whole. The WU11 type S cable is available length up to a maximum of 100 meter (328ft).

2.3.2 Connection in daisy chain concept

The YOKOGAWA HOST system model FLXA402 can be connected to maximum five SA11 devices. In case of more than two SA11 devices connected, the BA11 Active Junction Box must be used. Connection in between the FLXA402 and BA11 is done by using the WU11 type -S interconnection cable with at one end wired terminals and on the other end a M9 connector. Connection in between the BA11 and the SA11 is done using the WU11 type -S interconnection cable with at both ends a M9 connector. In both cases the maximum length has to be within 100 meter (328ft).

2.3.3 Wireless connection

In laboratory environments the HOST Fieldmate system can be connected to the SA11 using the YOKOGAWA Bluetooth device model IB100. Interconnection in between the IB100 and SA11 is done using the WU11 type -S interconnection cable with at both ends a M9 connector. The wireless communication in between the Fieldmate system and IB100 is limited to a distance of 10 meter.

NOTE: The intrinsically safe model of the SA11 needs to be connected to the intrinsically safe model IB100 to guarantee safe installation afterwards. For installation details see User Manual IB100.

Grounding

The measuring system must always be connected to a class D ground (a ground resistance of 100 Ohm or less), preferably done at the HOST side. To protect the SA11 device against interference, such as electromagnetic noise or common mode, all wires in WU11 type -S cable are connected at HOST. This makes the housing of the SA11 grounded. For correct measurement without loss of specifications, it is strongly recommended to ensure that the process liquid is grounded. Figure 2.4 shows the connection diagram in case without/UM option.

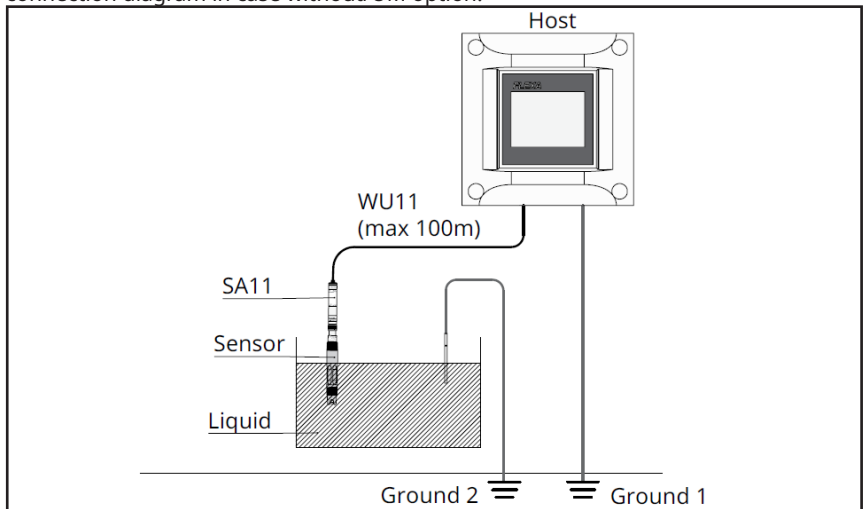

Figure 2.4: Typical installation of SA11 to host

However, in case that there is different potential between Ground at HOST side and Ground which the housing of the SA11 is connected, figure 5.5 shows the example of the installation. To prevent ground loop by this different potentials it is necessary to disconnect one of the ground references. This can be done at the HOST side by disconnecting the wire #82 of the WU11 type S cable. Please connect #82 to NC terminal on the SENCOM SA module when SA11 is connected to FLXA402. Please be sure to insulate contact pin of #82 wire from terminals and metal housing, when SA11 is connected to other host. The SA11 device must then be installed using the optional pipe and wall mounting hardware (/UM) with a ground wire connected in between the ground terminal of the mounting bracket and the ground reference of the process.

Alternate way to prevent ground loop is to isolate the SA11 & mounting plate from ground 2 & keep the terminal 82 connected.

Remark: For the installation shown in Figure 2.5, in case the ground references at the HOST side (Ground 1) and process side (Ground 2) have no potential difference the shield wire of the WU11 type -S cable (wire #82) can stay connected to the (pre-defined) ground terminal at the HOST.

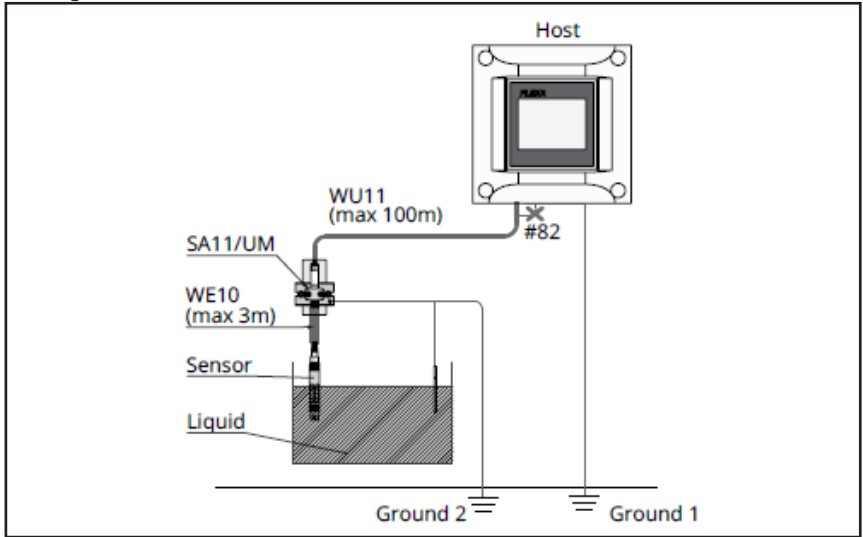

Figure 2.5: Typical installation example to prevent ground loop

In combination with Host who does not have grounding terminal to still meet the statutory regulations it is necessary to ground either the SA11 enclosure (e.g. by using the option /UM) or ground the shield of the cable. An example is shown in figure 2.6.

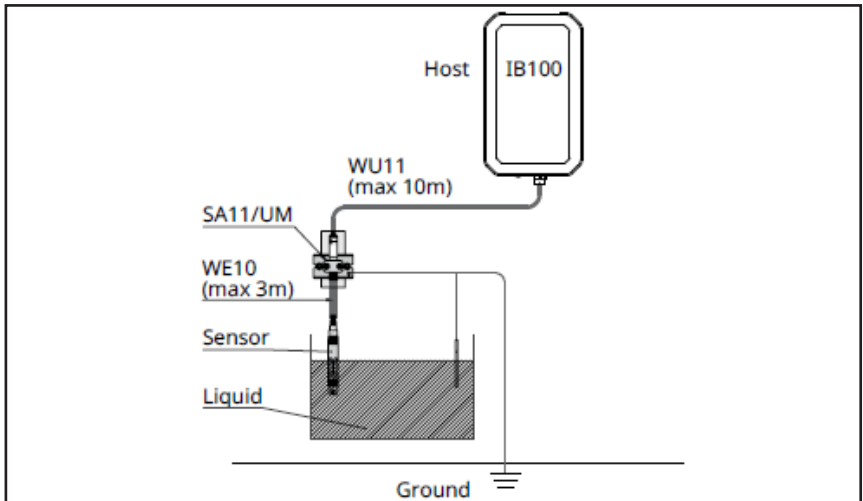

Figure 2.6: Installation example SA11 & IB100 to prevent interference

2.3.4 Control drawings

D&E 2019-024-A60: FM Control Drawing - United States

Non-hazardous Location

Hazardous Location

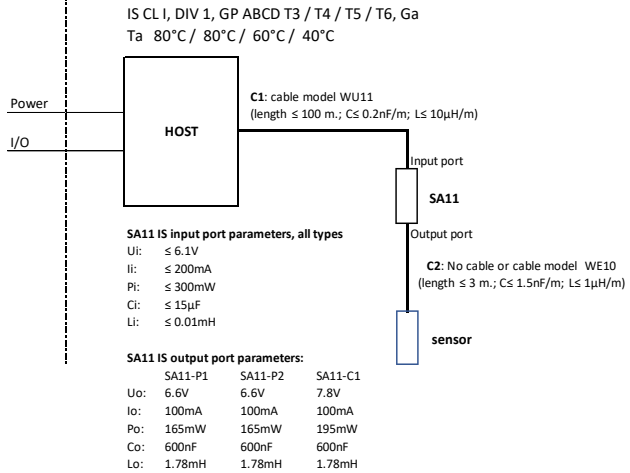

Specific conditions of use:

- Potential electrostatic charging hazard – When the equipment is used in hazardous locations, avoid any actions which generate electrostatic discharge, such as rubbing with a dry cloth.
- Potential ignition-capable earth currents – The Input Port connections incorporate an earthed conductor. Care shall be taken to prevent ignition-capable earth currents resulting from differing earth potentials between the SA11 and Host. Refer to section 5-3 of manufacturer’s Start-Up Manual 12A06S01 for instructions concerning earthing and isolation of the SA11.

Remarks:

1. No revision to this drawing without prior approval of FM.
2. Installation must be in accordance with the National Electrical Code (ANSI/NFPA 70), ANSI/ISA-RP12.06.01, and relevant local codes.
3. The SA11 shall be installed to a certified intrinsically safe HOST with the following maximum values:
U_o= 6.1 V, I_o = 200 mA, P_o = 300mW
4. SA11 Model code:

Model	Suffix Codes	Option Codes
SA11	·ab·cd·e·fg·hi	/j

- | | | | |
|----|----------------------|--|----------------------|
| ab | Measuring parameter: | C1 | Contact Conductivity |
| | | P1 | pH/ORP, conventional |
| | | P2 | pH/ORP, differential |
| cd | Type: | CD | IS for FM, CSA |
| e | Region: | One alphanumeric character (A to Z, 0 to 9 or hyphen)
Region code specification not affecting intrinsic safety | |
| fg | Connection type: | VS | Variopin connector |
| hi | Spare code: | Two alphanumeric characters (A to Z, 0 to 9 or hyphen).
Spare code specification not affecting intrinsic safety | |
| j | Option code: | Up to ten alphanumeric characters (A to Z, 0 to 9 or hyphen) | |

5. WARNING – POTENTIAL ELECTROSTATIC CHARGING HAZARD – SEE INSTRUCTIONS
WARNING – POTENTIAL IGNITION-CAPABLE EARTH CURRENTS – SEE INSTRUCTIONS

D&E 2019-024-A61: FM Control Drawing - Canada

Non-hazardous Location

Hazardous Location

IS, SJ, CL I, DIV 1, GP ABCD T3 / T4 / T5 / T6, Ga
 Ta 80°C / 80°C / 60°C / 40°C

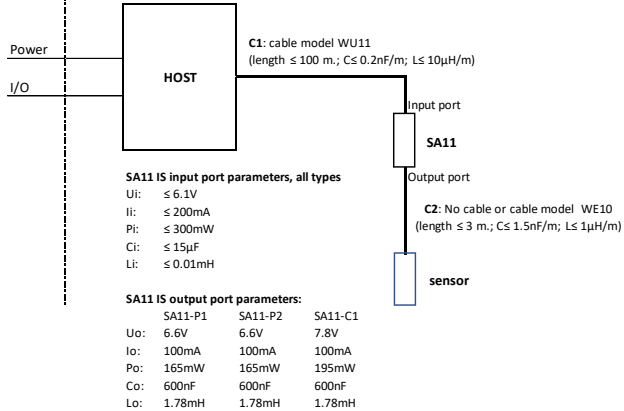

Specific conditions of use:

- Potential electrostatic charging hazard – When the equipment is used in hazardous locations, avoid any actions which generate electrostatic discharge, such as rubbing with a dry cloth.
- Potential ignition-capable earth currents – The Input Port connections incorporate an earthed conductor. Care shall be taken to prevent ignition-capable earth currents resulting from differing earth potentials between the SA11 and Host. Refer to section 5-3 of manufacturer’s Start-Up Manual 12A06S01 for instructions concerning earthing and isolation of the SA11.

Remarks:

1. No revision to this drawing without prior approval of FM.
2. Installation must be in accordance with Canadian Electrical Code (CEC) CSA C22.1, and relevant local codes.
3. The SA11 shall be installed to a certified intrinsically safe HOST with the following maximum values:
 Uo = 6.1 V, Io = 200 mA, Po = 300mW
4. SA11 Model code:

Model	Suffix Codes	Option Codes
SA11	-ab-cd-e-fg-hi	/j

- ab Measuring parameter: C1 Contact Conductivity
 P1 pH/ORP, conventional
 P2 pH/ORP, differential
- cd Type: CD IS for FM, CSA
- e Region: One alphanumeric character (A to Z, 0 to 9 or hyphen)
 Region code specification not affecting intrinsic safety
- fg Connection type: VS Variopin connector
- hi Spare code: Two alphanumeric characters (A to Z, 0 to 9 or hyphen).
 Spare code specification not affecting intrinsic safety
- j Option code: Up to ten alphanumeric characters (A to Z, 0 to 9 or hyphen)

5. WARNING – POTENTIAL ELECTROSTATIC CHARGING HAZARD – SEE INSTRUCTIONS
 AVERTISSEMENT – DANGER POTENTIEL DE CHARGES ÉLECTROSTATIQUES – VOIR LES INSTRUCTIONS
 WARNING – POTENTIAL IGNITION-CAPABLE EARTH CURRENTS – SEE INSTRUCTIONS
 AVERTISSEMENT – COURANTS DE TERRE POTENTIONNELS CAPABLES À L'ALLUMAGE – VOIR LES INSTRUCTIONS

D&E 2019-024-A62: ATEX/IECEx Control Drawing

Non-hazardous Location

Hazardous (Classified) Location

IECEx: Ex ia IIC Ga
ATEX: II 1 G Ex ia IIC Ga

Temperature Class: T3 / T4 / T5 / T6 for Ta +80°C / +80°C / +60°C / +40°C

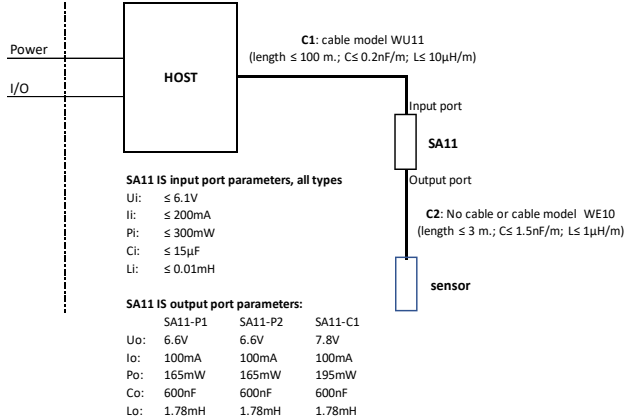

Specific conditions of use:

- Potential electrostatic charging hazard – When the equipment is used in hazardous locations, avoid any actions which generate electrostatic discharge, such as rubbing with a dry cloth.
- Potential ignition-capable earth currents – The Input Port connections incorporate an earthed conductor. Care shall be taken to prevent ignition-capable earth currents resulting from differing earth potentials between the SA11 and Host. Refer to section 5-3 of manufacturer’s Start-Up Manual 12A06S01 for instructions concerning earthing and isolation of the SA11.

Remarks:

1. No revision to this drawing without prior approval of FM.
2. Installation must be in accordance with IEC60079-14 and relevant local codes.
3. The SA11 shall be installed to a certified intrinsically safe HOST with the following maximum values:
Uo = 6.1 V, Io = 200 mA, Po = 300mW
4. SA11 Model code:

Model	Suffix Codes	Option Codes
SA11	-ab-cd-e-fg-hi	/j

- ab Measuring parameter:
 - C1 Contact Conductivity
 - P1 pH/ORP, conventional
 - P2 pH/ORP, differential
- cd Type:
 - CB IS for ATEX, IECEx
- e Region:
 - One alphanumeric character (A to Z, 0 to 9 or hyphen)
 - Region code specification not affecting intrinsic safety
- fg Connection type:
 - VS Variopin connector
- hi Spare code:
 - Two alphanumeric characters (A to Z, 0 to 9 or hyphen).
 - Spare code specification not affecting intrinsic safety
- j Option code:
 - Up to ten alphanumeric characters (A to Z, 0 to 9 or hyphen)

5. WARNING – POTENTIAL ELECTROSTATIC CHARGING HAZARD – SEE INSTRUCTIONS
 WARNING – POTENTIAL IGNITION-CAPABLE EARTH CURRENTS – SEE INSTRUCTIONS

3 OPERATION OF pH/ORP

3.1 SA11 quick setup

Select a Yokogawa pH/ORP electrode equipped with an ID-chip which is suitable for the process. When connected to the SA11 and powered, part of the setup of the SA11 will be done automatically by reading the content of the ID-chip of the sensor. These are sensor characteristics, factory calibration data, customer calibration data, diagnostics and loggings of calibration and events. See section 4 and 5 for details. Other setups have to be done by the Yokogawa HOST system, for details see the belonging User's Manual.

3.2 Measurement setup

3.2.1 Parameter setting

The SA11 measures and calculates process parameters, for details see section 4. The suitable measurement parameter(s) for display and process control can be set by the Yokogawa HOST system, for details see the belonging User's Manual.

3.2.2 Temperature setting

The SA11 measures process temperature in Celsius (°C) or Fahrenheit (°F). Setup of the temperature unit is done by the Yokogawa HOST system, for details see the belonging User's Manual.

3.3 pH/ORP zero, slope and impedance

3.3.1 Zero

The ZERO is the calibrated sensor offset in mV. Theoretically, the sensor reads 0 mV in a buffer solution of pH7. The ZERO value indicates the condition of the sensor. The trend of ZERO drift of the sensor is used to predict the lifetime of the sensor. ZERO can also be displayed in pH units and then it represents the pH value where the sensor output is 0 mV at 25°C. Settings can be done with the Yokogawa HOST system, for details see the belonging User's Manual.

3.3.2 Slope

The SLOPE is the calibrated efficiency of the sensor unit as a percentage of the theoretical slope of the sensor unit. The theoretical slope follows the NERNST equation and is 59.16 mV/pH (at 25°C). The SLOPE can be calibrated only after a two- or a three point calibration in buffer solutions with a different pH value. A low slope indicates that the sensor is not clean or is faulty.

The SLOPE can also be displayed as mV/pH at 25°C. Settings can be done with the Yokogawa HOST system, for details see the belonging User's Manual.

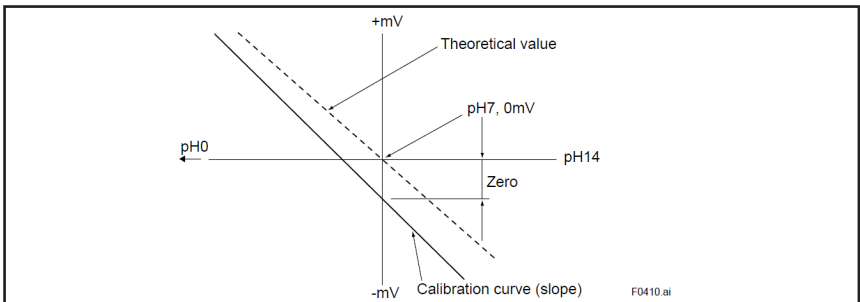

Figure 3.1: Zero/slope example

3.3.3 Impedance

The SA11 can measure the condition of the electrodes connected. This is done by measuring the electrical resistance, and this can be either high-ohmic or low-ohmic. If the impedance measurement is set as high-ohmic, the measurement is used for glass break detection. The detection limit is set automatically by the sensor characteristics. In case the impedance measurement is set as low-ohmic, the measurement is used for fouling and dry fall detection. Detection limits to be set by Yokogawa HOST system.

The SA11 impedance measurement depends on the device type and connected sensor.

- SA11-P1 type in combination with a pH sensor with Liquid Earth (LE) element: The SA11 measures both the electrical resistance of the high-ohmic glass membrane electrode and the electrical resistance of the low-ohmic reference electrode liquid junction. The liquid junction forms the electrolytic contact between the liquid earth and the reference electrode. It must be kept clean and filled with conductive electrolyte otherwise the measurement will suffer from instability, drift and measuring errors.
- SA11-P1 type in combination with a pH sensor without Liquid Earth element: The SA11 measures only the electrical resistance of the high-ohmic glass membrane-electrode.
- SA11-P2 type in combination with a pH sensor with Liquid Earth element: The SA11 measures the electrical resistance of the two high-ohmic glass membrane-electrodes.

In cases where a Liquid Earth is suitable for ORP measurement, the impedance value is based upon the electrical resistance of the low-ohmic reference. For an ORP-pH compensated measurement the impedance value is based upon the electrical resistance of the (high-ohmic) glass membrane reference.

3.4 Diagnostics

3.4.1 Liquid Earth (LE) detection

If a Yokogawa sensor with ID-chip is connected to a SA11-P1 type, the sensor characteristics explains if LE element is available or not. If available, the SA11 will activate the LE detection. If LE wiring is broken, an error will be flagged. If a Yokogawa sensor with ID-chip is connected to a SA11-P2 type, the LE element is always available. The LE detection is active and if LE wiring is broken an error will be flagged.

3.4.2 Device state

The operating mode of the SA11 is reflecting the device state. Except from the standard operating mode there are four other modes:

- Sleep mode (all calculations disabled)
- Calibration
- HOLD
- Safely remove (this is not a function of Yokogawa HOST systems)

3.4.3 Calibration due

Calibration due is the date when the calibration must be done next according to the settings of the calibration interval. The calibration intervals are set by the Yokogawa HOST system, for details see the belonging User's Manual.

3.4.4 Last calibrated

The last calibrated is the date on which the last sensor calibration was performed. For ZERO the displayed value is date of this last calibration. For SLOPE the displayed value is the date that the last 2-point calibration is executed.

3.4.5 Predictive maintenance

There are two kinds of predictive maintenance:

- Predictive sensor maintenance, which predicts the date when the sensor will need recalibrating for maintaining measurement accuracy. The function checks the low-ohmic reference impedance every 24 hours. The function predicts the date when the reference impedance will cross the upper or lower limits set by the Yokogawa HOST system, and indicates the date and its reliability status. The date is predicted based on the intersection point of the upper or lower limits and the extrapolated line of the values obtained by the least squares method.

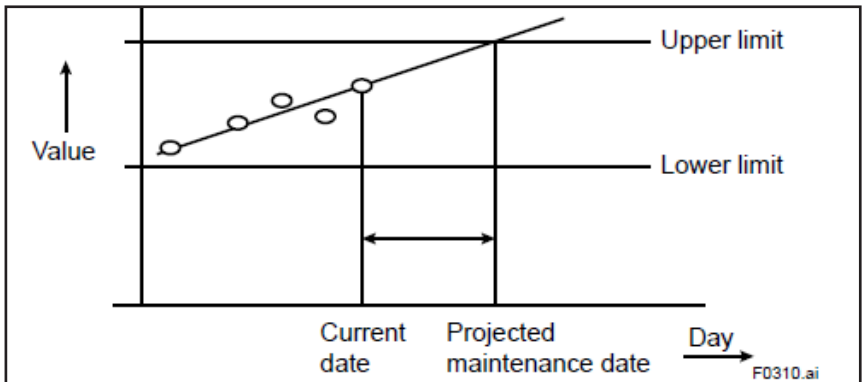

Figure 3.2: Predictive sensor maintenance date

- **Predictive sensor replacement**, which predicts the date when the sensor will need replacement. The date is based on the pH ZERO and pH SLOPE on each calibration, and the measured low-ohmic reference impedance. The date is predicted based on the best status of correlation in those three parameters. If some parameters have the same status, the nearest date is selected. The function indicates the date and its reliability status.

3.4.6 Sensor wellness

The SA11 can calculate the performance status of the sensor connected. The calculated result depends on user programmable settings done in the Yokogawa HOST system, and the sensor diagnostics data stored in the ID-chip of the sensor. When a sensor is replaced or exchanged, a reset of the wellness data is not necessary. If a user wants to reset this data anyhow, this is possible by the Yokogawa HOST system. For details see the belonging User's Manual.

There are seven (7) different wellness statuses for pH:

- ZERO
- SLOPE
- IMP1
- IMP2
- Progress time
This is the time in between 0 and actual operating hours of the sensor.
- Heat cycle
This is a counter which counts the settable temperature step changes (up or down) of a sensor.
- Total
This state indicates the worst wellness state of those activated.

Each wellness status can be set ON or OFF. If activated, the status is measured as a ratio of the actual value against the calculated value obtained from settings of lower limit and upper limit. For limit setting see Appendix 1. The status is indicated as a number in between 0 (bad) and 4 (good).

3.4.7 Sensor status

The SA11 monitors some process conditions of the connected sensor:

- **Maximum temperature exposed**, which is automatically updated every time a higher process temperature is measured.
- **High temperature 1/High temperature 2**, which is the total time at which the sensor is exposed above the corresponding limits, set by the Yokogawa HOST system. The last date and time (the end of high-temperature condition) is stored.
- **Sterilization**, which reflects the number of times at which the temperature remains above the preset value for at least the prescribed time period set by the Yokogawa HOST system.

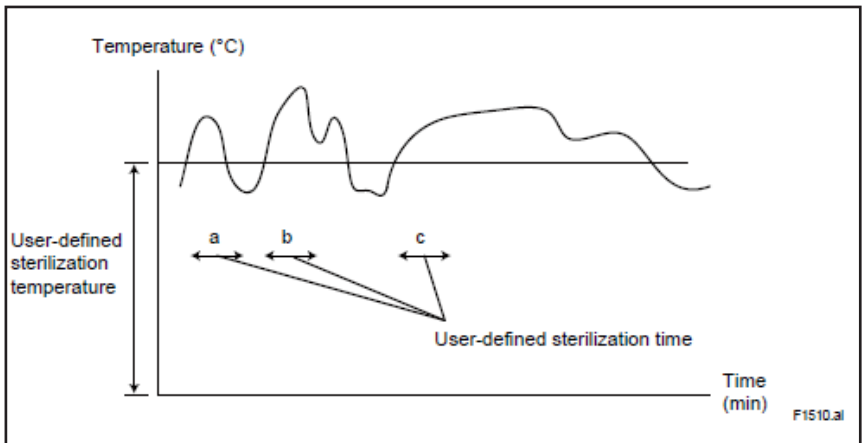

Figure 3.3: Example of sterilization

- a. This event is not counted because the duration does not reach the prescribed sterilization time.
- b. This event is counted because the duration exceeds the prescribed sterilization time.
- c. This event is counted because the duration exceeds the prescribed sterilization time. However long the event lasts, it is counted as one. The number of counts is up to 9999. The date and time of the last count is stored even when the maximum number of counts is reached.

- **High pH total time/Low pH total time**, which is the total time the sensor is exposed above the preset upper pH limit or below the preset lower pH limit. Settings of these limits can be done by the Yokogawa HOST system, for details see the belonging User's Manual.

3.5 Output setup

The SA11 Smart Adapter is normally always in operation mode. Only a dedicated HOST (FLXA402 expert HOST) can set the SA11 in three (3) other modes:

- **Sleep**, all operations will result in disabled output data. Communication however is still active.

- **HOLD**, calculated output data will be set in a fixed value:

- o Last value

- o Max. limit (hardcoded limits of SA11 which can be overruled by expert HOST)

- o Min. limit (hardcoded limits of SA11 which can be overruled by expert HOST)

- o Not a number (no result of calculated output data)

When in HOLD, only the output data is 'frozen'. All other operations will remain active.

- **Safely remove**, whereby it is safe to remove the SA11 without the risk of losing data.

3.6 Calibration and Commissioning

Allows the user to calibrate and configure the SA11 device. For details see section 4 and section 5.

4 COMMISSIONING OF pH/ORP

On the first startup, the parameters are all default values configured at the factory. For factory defaults and setting limits see Appendix 1. If a Yokogawa sensor with ID-chip is connected to the SA11 some of these values are automatically updated. These are sensor characteristics and factory calibration data. Other values can be configured by the Yokogawa HOST system, for details see the belonging User's Manual.

4.1 Measurement setup

This section describes the features of the SA11 Smart Adapter and which parameters can be set up by a HOST system. In principle the SA11 calculates all values, some with a particular unit, and it is up to the HOST system which values to configure, display or use for process control. The SA11 main measurement parameter outputs are:

- pH
- ORP1 (standard ORP value, voltage in between metal- and reference electrode)
- ORP2 (ORP-pH compensated value, voltage in between metal- and glass electrode)
- rH
- Temperature
- Impedance

If the SA11 is connected to a Yokogawa sensor with ID-chip not suitable to measure ORP (e.g. if no LE element is present or a LE element not suitable to measure ORP), the ORP calculated output data is disabled.

In case of a SA11-P1 type, and a sensor without LE, some features will be disabled or restricted:

- Reference impedance check (see section 3.3.3) and reference impedance error diagnostics: disabled
- ORP calculated output and ORP error diagnostics: disabled
- rH calculated output and rH error diagnostics: disabled
- Predictive sensor replacement (see section 3.4.5): restricted to pH ZERO and pH SLOPE only
- LE detect (see section 3.4.1) and LE error diagnostics: disabled

4.1.1 Measurement select

In general the SA11 calculates all parameter output data. The measurement warnings (see section 4.3) demand a pre-setting of the parameter. Per parameter one setting (to be done by HOST system) is possible for:

- pH pH, pH-TC, pH-matrix or pH-NEN 6411 (see section 4.1.4)
- ORP ORP1, ORP1-TC, ORP2, ORP2-TC

4.1.2 Temperature settings

The automatic temperature measurement with a SA11 Smart Adapter is based upon a Pt1000 temperature element. It is possible to set the temperature to a fixed manual temperature or to an external temperature which is regularly set by the HOST system.

4.1.3 Temperature compensation

The pH value generated by a pH sensor depends on the process temperature, and needs to be compensated for this temperature. The compensation of this pH value is performed on the Nernst equation.

Note: ORP value does not depend on process temperature.

4.1.4 Process compensation

The pH/ORP value can be compensated for specific temperature dependent process conditions.

- **Reference temperature**

For the temperature dependent process compensation a reference temperature has to be set to which the pH/ORP value must be calculated. Normally 25°C is used, so this temperature is chosen as the default value.

- **TC**

It is possible to adjust the temperature coefficient (TC) factor directly. This method uses the linear compensation function. If the temperature coefficient factor of the sample liquid is known from laboratory experiments or has been previously determined, it can be set. This TC is a pH variation to 1 °C ($\Delta\text{pH}/\Delta\text{T}$). In combination with the reference temperature setting, a linear compensation function is obtained, which is suitable for all kinds of chemical solutions.

- **Matrix**

This is compensation which uses the temperature compensation matrix. The temperature compensation matrix is a table of pH values at various temperatures, corresponding to the pH values at the standard temperature. For details see Appendix 2. The compensation is active up to 10°C and/or 1 pH deviation outside the values given in the matrix table. In this case the temperature compensation is performed by extrapolation of the matrix values. When temperature or pre-compensated value is outside this deviation range, no calculated value will be generated.

- **NEN6411**

This algorithm takes into account the dissociation of water in strong acid and strong alkaline solutions. It is particularly useful for pH measurement of boiler feed water.

4.1.5 pH settings

pH is the result of the measurement in between the pH glass membrane and the reference electrode. The characteristics for pH measurement are an offset (ZERO) and a SLOPE. For an ideal sensor, the theoretical slope is 59.16 mV/pH (at 25°C). The ZERO can be entered in pH or mV. The SLOPE can be entered in mV/pH or as a percentage of the theoretical slope (100% corresponds to 59.16 mV/pH).

ITP (Isothermal Point) represents a pH value where the output of the sensor does not change with temperature. Note that SLOPE and ZERO are both defined at 25°C.

The ZERO, SLOPE and ITP can be set for calculation of the pH value. When the SA11 is connected to a Yokogawa sensor with ID-chip the latest values are automatically updated. When afterwards these values are set by the HOST system or set by a renewed calibration of the sensor, these values will be active for calculation and stored in the sensor too.

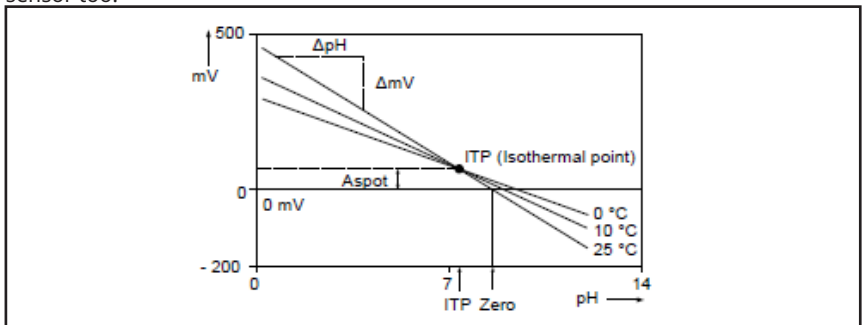

Figure 4.1: pH characteristic

4.1.6 ORP settings

ORP1 is the result of the voltage measurement in between the reference electrode and the Liquid Earth element (LE). ORP2 is the result of the voltage measurement in between the pH glass membrane and the Liquid Earth element (LE). The characteristics for ORP measurement are an offset, also known as ZERO [mV], and a SLOPE [%]. For an ideal sensor the theoretical slope is 100%.

4.1.7 rH settings

rH is a calculation based upon a pH value and a ORP1 value which results in a ORP value independent of pH.

4.1.8 Impedance settings

IMP represents impedance check, which can be configured for both inputs of the SA11. Both IMP1 and IMP2 can be configured for high (high-ohmic glass membrane impedance) or low (low-ohmic impedance of reference electrode). If configured as high the check is done on glass breakage (fixed value), low means setting for membrane resistance (user configurable values). Configuration has to be done by the Yokogawa HOST system, but settings are overruled by the information pre-programmed in the ID-chip of the connected sensor.

4.1.9 Unit conversion

• Temperature unit

The temperature can be set in Celsius (°C) or Fahrenheit (°F). If the unit is changed by the HOST, the following values are also recalculated automatically to the new unit:

- o Manual temp.
- o Reference temp.
- o Temp. coefficient
- o Temp. ranges in the matrix

• ZERO

The ZERO can be set in pH or mV, which is in line with the DIN standard for an IEC 60746-2 instrument.

• SLOPE

The SLOPE can be set in mV/pH or percentage (%).

4.1.10 Calibration settings for pH/ORP1/ORP2

For calibration it is needed to set acceptance limits, see Appendix 1 for details. Settings have to be done by HOST system.

• Limits and timing

- o ZERO High/Low limits for pH/ORP1/ORP2:
 - During calibration, it is checked whether the new ZERO exceeds these high and low limits. Narrowing the band will prevent bad calibration procedures and calibration of bad sensors, which results in higher accuracy. The default values should be adjusted to suit the application and the “users” criterion.
- o SLOPE High/Low limits for pH/ORP1/ORP2 :
 - During calibration, it is checked whether the new SLOPE exceeds these high and low limits. Narrowing the band will prevent bad calibration procedures and calibration of bad sensors, which results in higher accuracy. The default values should be adjusted to suit the application and the “users” criterion.
- o Step Range for pH/ORP:
 - Set the range over which the stability of a measured value is checked. If variations of a measured value over the stabilization time are within this set value, the measured value is judged to have stabilized.

o Stabilization time for pH/ORP:

During calibration, the stability of the pH value is constantly monitored. When variations of the pH value during this stabilization time are within a value set in Step Range, the value is regarded as being stable. If the measurement value does not stabilize within the time set for stabilization (default 5 seconds), the calibration procedure is aborted.

o Calibration interval:

Set the interval in which a new calibration must take place. If the interval set here is exceeded, the SA11 will notify according to the setting in "Calib. time exceeded" in the error configuration.

• **Buffer select**

Calibration is made using standard calibration buffers. Yokogawa recommends the NIST (JIS equivalent) standard buffers for highest accuracy, but can also select DIN 19267 or US. The standard buffers can be found in Appendix 2.

It is even possible to use a user-defined buffer. Three types of user-defined buffer tables can be defined. These buffer tables are default defined as sodium buffers 4.00, 7.00 and 10.00. The buffer tables have to be set by an expert Yokogawa HOST system.

4.2 Communication setup

The SA11 is a slave device communicating with a HOST system using MODBUS protocol. For correct communication the following settings can be made:

• **MODBUS address**

The MODBUS address (Slave ID) is default set to 1, but can be set by HOST system to another address in between #1 and #247.

• **Serial profile**

MODBUS is an application layer messaging protocol which provides client/server communication between devices connected on different types of buses/networks. The SA11 is able to communicate with two predefined serial profile settings, to be selected by the HOST system, which is default set to 1:

1. 9600 bps, 8 bits, even parity, 1 stop bit
2. 19200 bps, 8 bits, no parity, 2 stop bits

4.3 Error configuration

The SA11 contains error diagnostics, which is a summary of all related measurement warnings, diagnostics, sensor statuses and other kind of failures. Part of the configuration will be pre-defined by the sensor configuration as stored in the ID-chip.

Errors can be defined in different levels: critical and fail. An error will always result in noncalculated output data or a pre-defined value. These errors and related limits are not user configurable.

Beside this there are configurable measurement warnings. A warning is only a flag and has no consequence for calculated output data.

At last there are sensor- and device statuses which reflect a certain state of performance and/or operations. A sensor failure can result in a critical device error.

The SA11 show the four (4) categories:

- Critical device errors
- Sensor failures and sensor statuses
- Measurement warnings on calculated outputs
- Device status

Table 4.1: Critical device errors

Error item	Result for output data
NVM (note 1)	Not a number (note 2)
User data CRC (note 3)	Not a number
Factory data CRC	Not a number
SA11 not working	Not a number
Critical sensor failure	Not a number
ID-chip sync	Not a number
Temp. too high (note 4)	Max. limit (set by HOST for +260°C / +500°F or +140°C / +284°F)
Temp. too low (note 4)	Min. limit (set by HOST for -40°C / -40°F or -30°C / -22°F)
pH voltage too high	Max. limit (+750 mV)
pH voltage too low	Min. limit (-750 mV)
ORP1 voltage too high	Max. limit (+1500 mV)
ORP1 voltage too low	Min. limit (-1500 mV)
ORP2 voltage too high	Max. limit (+1500 mV)
ORP2 voltage too low	Min. limit (-1500 mV)
SA11 internal temp. outside limits (note 5)	Not a number

Note 1: NVM= Non Volatile Memory which is a type of memory that can retrieve stored information from SA11 even after a power down.

Note 2: Not a number means that there is no result of calculated output data.

Note 3: CRC = Cyclic Redundancy Check, which is data verification.

Note 4: Limit set depends on capabilities of the HOST system.

Note 5: SA11 has an internal temperature element which measure temperature of electronics. If the design temperature is outside the limits of -40°C up to +130°C an error will be flagged.

Table 4.2: Sensor failures and sensor statuses

Failure/status item	Result for output data
Sensor detect	Not a number
Temp. element detect	Not a number
ID-chip detect	Not a number
Liquid Earth (LE) detect (note 1)	None
Calibration due	None
Sensor safely remove (note 2)	None
Glass breakage on input 1 (note 3)	Not a number
Glass breakage on input 2 (note 3)	Not a number

Note 1: In case of a sensor without LE element, the Liquid Earth (LE) detect is switched to inactive.

Note 2: In case of sensor safely remove there will be no up date of data to sensor ID until reset.

Note 3: Failure detection active only in case that IMP1 and/or IMP2 setting being high. This setting is done by ID-chip content of the sensor.

Table 4.3: Measurement warnings on calculated outputs

Failure too high means that the calculated output value is higher than the user configured limit. Failure too low means that the calculated output value is less than the user configured limit.

Warning item	Warning based upon conditions set
Temp. too high	Limit, to be configured by user from -40°C / -40°F or -30°C / -22°F up to +260°C / +500°F or +140°C / +284°F
Temp. too low	Limit, to be configured up to -40°C / -40°F or -30°C / -22°F up to +260°C / +500°F or +140°C / +284°F
pH too high	Limit, to be configured by user from -2 pH up to 16 pH
pH too low	Limit, to be configured by user from -2 pH up to 16 pH
ORP too high (note 1)	Limit, to be configured by user from -1500 mV up to +1500 mV
ORP too low	Limit, to be configured by user from -1500 mV up to +1500 mV
rH too high	Limit, to be configured by user from 0 up to 100
rH too low	Limit, to be configured by user from 0 up to 100
IMP1 too high (note 2)	Limit, to be configured by user from 1 (k Ω) up to 1000 (k Ω)
IMP1 too low (note 2)	Limit, to be configured by user from 1 (k Ω) up to 1000 (k Ω)
IMP2 too high (note 2)	Limit, to be configured by user from 1 (k Ω) up to 1000 (k Ω)
IMP2 too low (note 2)	Limit, to be configured by user from 1 (k Ω) up to 1000 (k Ω)
pH temp. comp.	The temperature compensation is result of extrapolation of the matrix values (see section 4.1.4)
SA11 internal temp. outside operating limits	The internal temperature is outside the operating limits from -30°C up to +125°C

Note 1: ORP can mean ORP1 or ORP2, depends on ORP setting (see section 4.1.6).

Note 2: IMP1 and/or IMP2 measurement warning only active if IMP1/2 are configured as low.

- **Device status**

The device status represents activities of the SA11 device such as but not limited to calibration mode, HOLD mode and Sleep mode.

Note: In Sleep mode all operations to quarantine output data will be disabled. Communication remains active.

4.4 Logbook configuration

Logbooks are used to keep an electronic record of events such as error messages and calibrations. By referring to this log, users can, for instance, easily determine maintenance or replacement schedules.

The SA11 Smart Adapter will log events continuously during operation and calibration. Predefined events will be stored in a logbook. These events are distinguished in two types, calibration events and alarm events, each having their own logbook.

Each event contains the following data, each item 4 bytes:

- Date (based upon seconds starting from January 1st, 2000)
- Data
- Event number

For an overview of logbook events see Appendix 3.

Each logbook can store up to 50 events, of which the oldest event will be overwritten by the latest event. A copy of the logbooks is stored too in the ID-chip of the sensor connected. The logbook stored in the ID-chip of the sensor however is leading in case a sensor is replaced or reconnected. At that moment the content of the logbook of the sensor will overwrite the content of the logbooks of the SA11.

Only Yokogawa expert HOST, model FLXA402 and Fieldmate, can read each logbook of the SA11 and if necessary erase each logbook individually.

5 CALIBRATION OF pH/ORP

For accurate pH measurement it is important to calibrate a pH sensor regularly. The sensor is calibrated before shipment, and the calibration data is stored in the ID-chip of the sensor as factory defaults. It is recommended to re-calibrate the sensor before first use.

5.1 Temperature calibration

For the accuracy of calibration of pH/ORP, it is important to have a precise temperature measurement. Measure the temperature with a high-precision thermometer and adjust the sensor reading (temp. offset) accordingly. For best accuracy, this should be done as near to the normal operating temperature as possible.

5.2 pH calibration

There are four methods of calibration: Manual, Automatic, Sample and Fully Automatic calibration. Calibration is performed stepwise, and a stability check is conducted at each measurement point. For setting of this check see section 4.1.9. At calibration, we advise leaving the sensors for three to five minutes in the buffer solution before proceeding to the next step.

This will give reliable and accurate calibration results.

The SA11 has automatic buffer recognition for easy use and to prevent wrong sequence of actions. This is active only in case of fully automatic calibration.

For buffer selection see section 4.1.10.

Note: When a sensor is replaced or exchanged, a reset of the wellness data is not necessary. If a user wants to reset this data anyhow, this is possible by the Yokogawa HOST system. For details see the belonging User's Manual.

5.2.1 Manual calibration

The calculated output data for pH is adjusted to match the value of the buffer standards or a process solution with a known pH value. Setting is done by HOST for pH value, temperature compensation and stability (see sections 4.1.3, 4.1.4 and 4.1.5). Calibration type can be set for:

- **ZERO/SLOPE**

This calibration type is one-point or two-point calibration. One-point calibration performs the ZERO adjustment only. Two-point calibration performs the ZERO and SLOPE adjustments.

- **ZERO/SLOPE/ITP**

This calibration type is ITP-type three-point calibration.

If ITP does not have default pH 7, three-point calibration is performed to obtain the ZERO (asymmetry), SLOPE (sensitivity), and ITP (isothermal point).

Limitations:

- o Three different buffer solutions whose difference in pH value between buffer solutions is 1 pH or more should be used.
(1st buffer < 2nd buffer < 3rd buffer or 1st buffer > 2nd buffer > 3rd buffer)
- o The 2nd buffer solution should be pH 7 ± 2.
- o The temperature difference between the 2nd and 3rd buffer solutions should be 20°C or less.

The temperatures of the 2nd and 3rd buffer solutions should be at least 20°C higher or lower than the temperature of the 1st buffer solution.

NOTE When a Yokogawa sensor having an ID-chip is used, ITP-type three-point calibration is not necessary because ITP value of sensor is used as default.

• **ZERO/SLOPE1/SLOPE2 (3points)**

This calibration type is the line-segment type three-point calibration. If the relation between electromotive force and pH is not in proportion for a wide range, divide the relevant range into two sections and obtain the ZERO (asymmetry) and SLOPE (sensitivity) in each section to perform calibration.

Limitations

- o Three different buffer solutions whose difference in pH value between buffer solutions is 1 pH or more should be used.
(1st buffer < 2nd buffer < 3rd buffer or 1st buffer > 2nd buffer > 3rd buffer)
- o The temperature difference between the 1st and 2nd buffer solutions should be 20°C or less.
- o The temperature difference between the 2nd and 3rd buffer solutions should be 20°C or less.

5.2.2 Automatic calibration

Pre-select the buffer solution to be used, for details see section 4.1.9.

Calibration can be set the same as for manual calibration:

• **ZERO/SLOPE**

Select the solution that works with the “buffer solution” selected in calibration settings and perform calibration using the HOST system.

• **ZERO/SLOPE/ITP**

Calibration is performed in a sequence (predefined by HOST) of the solution that works with the “buffer solution” selected in calibration settings. Perform calibration using the HOST system.

Limitations:

- o Temperature during calibration must be within the limits of the selected buffer table.
- o Three different buffer solutions whose difference in pH value between buffer solutions is 1 pH or more should be used.
(1st buffer < 2nd buffer < 3rd buffer or 1st buffer > 2nd buffer > 3rd buffer)
- o The 2nd buffer solution should be pH 7 ± 2 (at 25°C).
- o Either of the following conditions should be met:
 - The temperature difference between the 1st and 2nd buffer solutions should be 20°C or less. The temperature of the 1st and 2nd buffer solutions is at least 20°C higher or lower than the temperature of the 3rd buffer solution.
 - The temperature difference between the 2nd and 3rd buffer solutions should be 20°C or less. The temperature of the 2nd and 3rd buffer solutions is at least 20°C higher or lower than the temperature of the 1st buffer solution.

5.2.3 Sample calibration

A sample calibration is a single-point calibration for only the ZERO (asymmetric). It adjusts the calculated output for pH to a collected sample value. Use the HOST to record a collected sample and to set SA11.

5.2.4 Fully Automatic calibration

The SA11 has automatic buffer recognition for easy use and to prevent wrong sequence of actions. This is active only when SA11 is in basic mode.

The SA11 will automatic recognize the buffer based upon a combination of a pre-defined buffer set and the actual mV value measured. When the measured value is within a specified range for pH value (fixed set on 1 pH) of one of the buffers selected, this buffer will be automatically used as input for the stability check.

Calibration is made using standard calibration buffers. Yokogawa recommends the NIST (JIS equivalent) standard buffers for highest accuracy, but can also select DIN 19267 or US. The standard buffers can be found in Appendix 2. It is even possible to use a user-defined buffer. Three types of user-defined buffer tables can be defined. These buffer tables are default defined as sodium buffers 4.00, 7.00 and 10.00. The buffer tables have to be set by an expert Yokogawa HOST system.

Limitations:

- Temperature during calibration must be within the limits of the selected buffer table.
- Two different buffer solutions whose difference in pH value between buffer solutions is 2 pH or more.
- Calibration method applicable only for one-point or two-point calibration.

5.3 ORP/rH calibration

The calibration modes for ORP or rH are "Manual" and "Sample" only. Calibration is performed stepwise. Follow the prompts displayed on the screen. A stability check is made at each measurement point. Proceed to the next step only after the reading has stabilized.

Note: When a sensor is replaced or exchanged, a reset of the wellness data is not necessary. If a user wants to reset this data anyhow, this is possible by the Yokogawa HOST system. For details see the belonging User's Manual.

6 OPERATION OF SC (Specific Conductivity)

6.1 SA11 quick setup

Select a Yokogawa specific conductivity sensor equipped with an ID-chip which is suitable for the process. When connected to the SA11 and powered, part of the setup of the SA11 will be done automatically by reading the content of the ID-chip of the sensor. These are sensor characteristics, factory calibration data, customer calibration data, diagnostics and loggings of calibration and events. See sections 7 and 8 for details. Other setups have to be done by the Yokogawa HOST system, for details see the belonging User's Manual.

6.2 Measurement setup

6.2.1 Parameter setting

The SA11 measures and calculates process parameters, for details see section 7. The suitable measurement parameter(s) for display and process control can be set by the Yokogawa HOST system, for details see the belonging User's Manual.

6.2.2 Temperature setting

The SA11 measures process temperature in Celsius (°C) or Fahrenheit (°F). Setup of the temperature unit is done by the Yokogawa HOST system, for details see the belonging User's Manual.

6.3 Cell constant & polarization

6.3.1 Cell constant

The SA11 device will be set automatically to the last calibrated cell constant value when connected to the sensor. When sensor is used the first time this last calibrated cell constant is the calibrated factory cell constant. This value is printed also on the label of the sensor. Beware that the information on the label, printed in a cell constant unit cm^{-1} , can differ with the information displayed by the HOST due to the possibility to set cell constant unit in cm^{-1} or m^{-1} .

6.3.2 Polarization

Applying an electrical current to electrodes in solution may cause an accumulation of ionic species near the electrode surfaces and chemical reactions at the surfaces. Thus, a polarization resistance arises on the electrode surface, which may lead to erroneous results as it is a parasitic component to the solution resistance. This effect is monitored by analyzing the signal of the conductivity sensor. If the effect of polarization leads to a difference in percentage from the actual value, the SA11 device will flag an error. Setting of percentage from 0% up to 50% is done by the Yokogawa HOST system, for details see the belonging User's Manual.

6.4 Diagnostics

6.4.1 Device state

The operating mode of the SA11 is reflecting the device state. Except from the standard operating mode there are four other modes:

- Sleep mode (all calculations disabled)
- Calibration
- HOLD
- Safely remove (this is not a function of Yokogawa HOST systems)

6.4.2 Calibration due

Calibration due is the date when the calibration must be done next according to the settings of the calibration interval. The calibration intervals are set by the Yokogawa HOST system, for details see the belonging User's Manual.

6.4.3 Last calibrated

The last calibrated is the date on which the last sensor calibration was performed. For cell constant the displayed value is date of this last calibration.

6.4.4 Predictive maintenance

Predictive sensor maintenance predicts the date when the sensor will need recalibrating for maintaining measurement accuracy.

The date is based upon the two sensor characteristics:

- **Polarization**, checked every 24 hours. The function predicts the date when the measurement value will cross the upper limit set by the Yokogawa HOST system, and indicates the date and its reliability status. The date is predicted based on the intersection point of the theoretical lower limit (0%) and the upper limit, and the extrapolated line of the values obtained by the least squares method.
- **Historical calibration data** of cell constant by analyzing the historical data of cell constant obtained by calibration. The function predicts the date when a new calibration will lead to a crossing of the upper limit or lower limit set for a difference (in percentage) in between the actual cell constant and the calibrated factory cell constant. The date is predicted based on the intersection point of the lower limit and the upper limit, and the extrapolated line of the values obtained by the least squares method. The date is predicted based on the best status of correlation in those two parameters. If some parameters have the same status, the nearest date is selected. The function indicates the date and its reliability status.

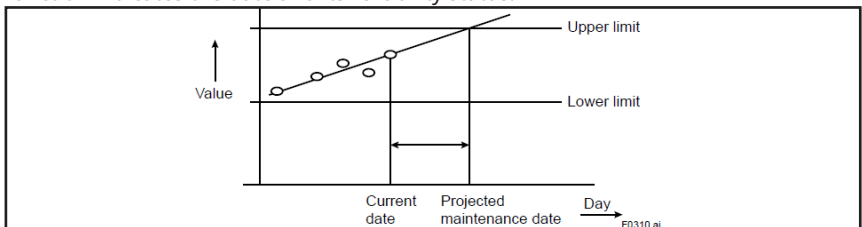

Figure 6.1: Predictive sensor maintenance date

6.4.5 Sensor wellness

The SA11 can calculate the performance status of the sensor connected. The calculated result depends on user programmable settings done by the Yokogawa HOST system, and the sensor diagnostics data stored in the ID-chip of the sensor.

When a sensor is replaced or exchanged, a reset of the wellness data is not necessary. If a user wants to reset this data anyhow, this is possible by the Yokogawa HOST system. For details see the belonging User's Manual.

There are five (5) different wellness statuses for SC:

- **Cell constant**
- **Polarization**
- **Progress time**, the time in between 0 and actual operating hours of the sensor.
- **Heat cycle** counter which counts the settable temperature step changes (up or down) of a sensor.
- **Total** indicating the worst wellness state of those activated.

Each wellness status can be set ON or OFF. If activated, the status is measured as a ratio of the actual value against the calculated value obtained from settings of lower limit and upper limit. For limit setting see Appendix 4. The status is indicated as a number in between 0 (bad) and 4 (good).

6.4.6 Sensor status

The SA11 monitors some process conditions of the connected sensor:

- **Maximum temperature exposed**, which is automatically updated every time a higher process temperature is measured.
- **High temperature 1/High temperature 2**, which is the total time at which the sensor is exposed above the corresponding limits, set by the Yokogawa HOST system. The last date and time (the end of high-temperature condition) is stored.
- **Sterilization**, which reflects the number of times at which the temperature remains above the preset value for at least the prescribed time period set by the Yokogawa HOST system.

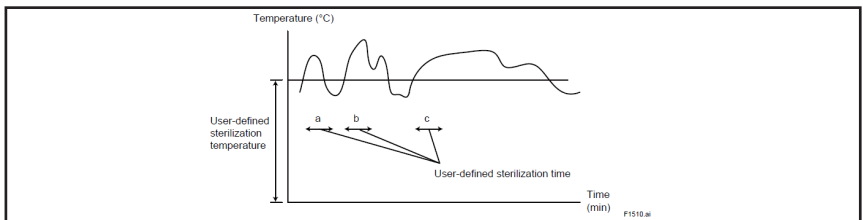

Figure 6.2: Example of sterilization

- a. This event is not counted because the duration does not reach the prescribed sterilization time.
- b. This event is counted because the duration exceeds the prescribed sterilization time.
- c. This event is counted because the duration exceeds the prescribed sterilization time.

However long the event lasts, it is counted as one.

The number of counts is up to 9999. The date and time of the last count is stored even when the maximum number of counts is reached.

6.5 Output setup

The SA11 Smart Adapter is normally always in operation mode. Only a dedicated HOST (FLXA402 expert HOST) can set the SA11 in three other modes:

- **Sleep**, all operations which result in output data will be disabled. Communication however is still active.
- **HOLD**, calculated output data will be set in a fixed value:
 - o Last value
 - o Maximum limit (hardcoded limits of SA11 which can be overruled by expert HOST)
 - o Minimum limit (hardcoded limits of SA11 which can be overruled by expert HOST)
 - o Not a number (no result of calculated output data)

When SA11 is in HOLD only the output data is 'frozen', all other operations are still active.

- **Safely remove**, whereby it is safe to remove the SA11 without the risk of losing data.

6.6 Calibration and Commissioning

Allows the user to calibrate and configure the SA11 device. For details see section 7 and section 8.

7 COMMISSIONING OF SC (Specific Conductivity)

On the first startup, the parameters are all default values configured at the factory. For factory defaults and setting limits see Appendix 4. If a Yokogawa sensor with ID-chip is connected to the SA11 some of these values are automatically updated. These are sensor characteristics and factory calibration data. Other values can be configured by the Yokogawa HOST system, for details see the belonging User's Manual.

7.1 Measurement setup

This section describes the features of the SA11 Smart Adapter and which parameters can be set up by a HOST system. In principle the SA11 calculates all values, some with a particular unit, and it is up to the HOST system which values to configure, display or use for process control. The SA11 main measurement parameter outputs are:

- Conductivity (SC)
- Resistivity (R)
- Concentration (Conc.) based on table (linear) or matrix
- Temperature

7.1.1 Measurement select

In general the SA11 calculates all parameter output data. The measurement warnings (see section 7.3) demand a pre-setting of the parameter. Per parameter however one setting (to be done by HOST system) is possible for:

- Output1: SC, SC-TC1, SC-NaCl, SC-matrix1, R, R-TC1, R-NaCl, R-matrix1
- Output2: SC, SC-TC2, SC-NaCl, SC-matrix2, R, R-TC2, R-NaCl, R-matrix2
- Conc1: Conc.-linear, Conc.-matrix1, Conc-output1
- Conc2: Conc.-linear, Conc.-matrix2, Conc-output2
- USP23

7.1.2 Temperature settings

The automatic temperature measurement with a SA11 Smart Adapter is based upon a Pt1000 temperature element. It is possible to set the temperature to a fixed manual temperature or to an external temperature which is regularly set by the HOST system.

7.1.3 Temperature compensation

The conductivity/resistivity value generated by a specific conductivity sensor depends on the process temperature, and needs to be compensated for this temperature.

7.1.4 Process compensation

The conductivity/resistivity value can be compensated for specific temperature dependent process conditions.

• Reference temperature

For the temperature dependent process compensation a reference temperature has to be set to which the conductivity/resistivity value must be calculated. Normally 25°C is used, so this temperature is chosen as the default value.

• TC1/2

It is possible to adjust the temperature coefficient (TC) factor directly. This method uses the linear compensation function. If the temperature coefficient factor of the sample liquid is known from laboratory experiments or has been previously determined, it can be set. This TC is a conductivity/resistivity variation in percentage to 1 °C (%/°C). In combination with the reference temperature setting, a linear compensation function is obtained, which is suitable for all kinds of chemical solutions.

- **NaCl**

This method uses the standard temperature compensation function based on a sodium chloride (NaCl) solution. This function can be used for various applications and is compatible with the NaCl compensation function of typical laboratory or portable instruments.

- **Matrix**

This is compensation which uses the temperature compensation matrix. The temperature compensation matrix is a table of conductivity values at various temperatures and various concentrations of a specific solution. The measured conductivity is compensated based on this matrix to the conductivity at the reference temperature. It is possible to select from a list of 12 predefined matrices, or create up to 2 user defined matrices by using HOST system. For details see Appendix 5.

The compensation is active up to 10°C and 10% outside the values given in the matrix table. In this case the temperature compensation is performed by extrapolation of the matrix values. When temperature or pre-compensated value is outside this deviation range, no calculated value will be generated.

7.1.5 Concentration

The concentration is a calculation from a known conductivity value related to a specific concentration of the process. This concentration calculation can be done using a matrix table or by linear interpolation using a concentration table.

The choice for which calculation method is used can be set by HOST system.

7.1.6 USP23

USP stands for United States Pharmacopeia, and is basically a conductivity monitoring system to meet USP23 regulations in the Pharmaceutical Industry.

The USP limit is based upon the predefined uncompensated conductivity values at a certain process temperature as directed by USP<645>. For details see Appendix 6.

If the uncompensated measured conductivity value at process temperature is more than the USP limit value, a USP limit warning is flagged.

To warn the user for an upcoming USP error, a USP margin can be set. This USP margin is set as a percentage of the USP limit. In case the uncompensated conductivity value is within this USP margin, a USP margin warning will be flagged. The HOST system can act in a proper way on these warning flags.

7.1.7 SC settings

The conductivity/resistivity is the result of the measurement with a specific conductivity sensor.

There are two (2) types of sensors which can be set:

- **2-electrode**, usually used for conductivity and/or resistivity measurements.
- **4-electrode**, meant to measure at high conductivity ranges where polarization of the electrodes may cause an error in conductivity measurement.

Sensors have a so-called cell constant (c.c.) which is defined by the mechanical structure of the sensor (length in between the electrodes divided by the surface of the electrode), which can be set in the unit cm⁻¹ or m⁻¹. The process values will be expressed in S/cm or S/m in conductivity mode, and Ω.cm or Ω.m in resistivity mode.

7.1.8 Unit conversion

- Temperature unit

The temperature can be set in Celsius (°C) or Fahrenheit (°F). If the unit is changed by the HOST, the following values are also recalculated automatically to the new unit:

- o Manual temp.
- o Reference temp.
- o Temp. coefficient
- o Temp. ranges in the matrix

7.1.9 Calibration settings for Conductivity/Resistivity

For calibration it is needed to set acceptance limits, see Appendix 8 for details. Settings have to be done by HOST system.

- **Limits and timing**

- o c.c. High/Low limits:

During calibration, it is checked if the new c.c. exceeds these high and low limits.

- o Step Range:

Set the range over which the stability of a measured value is checked. If variations of a measured value over the stabilization time are within this set value, the measured value is judged to have stabilized.

- o Stabilization time:

During calibration, the stability of the measurement value is constantly monitored. When variations of the measurement value during this stabilization time are within a value set in Step Range, the value is regarded as being stable. If the measurement value does not stabilize within the time set for stabilization (default 5 seconds), the calibration procedure is aborted.

- o Calibration interval:

Set the interval in which a new calibration must take place. If the interval set here is exceeded, the SA11 will notify according to the setting in "Calib. time exceeded" in the error configuration.

- **Standard solution (buffer) select**

Calibration is made using standard calibration solutions. Yokogawa recommends the standard buffers directed by DIN 53-779 for highest accuracy: 1.000M KCl, 0.100M KCl, 0.010M KCl and 0.005M KCl.

The standard buffer solutions can be found in Appendix 5.

7.2 Communication setup

The SA11 is a slave device communicating with a HOST system using MODBUS protocol. For correct communication the following settings can be made:

- **MODBUS address**

The MODBUS address (Slave ID) is default set to 1, but can be set by HOST system to another address in between #1 and #247.

- **Serial profile**

MODBUS is an application layer messaging protocol which provides client/server communication between devices connected on different types of buses/networks. The SA11 is able to communicate with two predefined serial profile settings, to be selected by the HOST system, which is default set to 1:

1. 9600 bps, 8 bits, even parity, 1 stop bit
2. 19200 bps, 8 bits, no parity, 2 stop bits

7.3 Error configuration

The SA11 contains error diagnostics, which is a summary of all related measurement warnings, diagnostics, sensor statuses and other kind of failures. Part of the configuration will be pre-defined by the sensor configuration as stored in the ID-chip. Errors can be defined in different levels: critical and fail. An error will always result in noncalculated output data or a pre-defined value. These errors and related limits are not user configurable. Beside this there are configurable measurement warnings. A warning is only a flag and has no consequence for calculated output data.

At last there are sensor- and device statuses which reflect a certain state of performance and/or operations. A sensor failure can result in a critical device error. The SA11 show the four (4) categories:

- Critical device errors
- Sensor failures and sensor statuses
- Measurement warnings on calculated outputs
- Device status

Table 7.1: Critical device errors

Error item	Result for output data
NVM (note 1)	Not a number (note 2)
User data CRC (note 3)	Not a number
Factory data CRC	Not a number
SA11 not working	Not a number
Critical sensor failure	Not a number
ID-chip sync	Not a number
Temp. too high (note 4)	Max. limit (set by HOST for +260°C / +500°F or +250°C / +482°F)
Temp. too low (note 4)	Min. limit (set by HOST for -40°C / -40°F or -20°C / -4°F)
Input resistance too high (note 5)	Max. limit (100MΩ)
Input resistance too low (note 5)	Min. limit (1Ω)
SA11 internal temp. outside design limits (note 6)	Not a number

Note 1: NVM= Non Volatile Memory which is a type of memory that can retrieve stored information from SA11 even after a power down.

Note 2: not a number means that there is no result of calculated output data.

Note 3: CRC= Cyclic Redundancy Check, which is data verification.

Note 4: Limit set depends on capabilities of the HOST system.

Note 5: Input resistance is the uncompensated 'raw' value.

Note 6: The SA11 has an internal temperature element which measure temperature of electronics. If the design temperature is outside the limits of -40°C up to +130°C an error will be flagged.

Table 7.2: Sensor failures and sensor statuses

Failure/status item	Result for output data
Sensor detect	Not a number
Temp. element detect	Not a number
ID-chip detect	Not a number
Calibration due	None
Sensor safely remove (note)	None

Note: In case of sensor safely remove there will be no up date of data to sensor ID until reset.

Table 7.3: Measurement warnings on calculated outputs

Failure too high means that the calculated output value is higher than the user configured limit. Failure too low means that the calculated output value is less than the user configured limit.

Failure/status item	Warning based upon conditions set
Temp. too high	Limit, to be configured by user from -40°C / -40°F or -20°C / -4°F up to +260°C / +500°F or +250°C / +482°F
Temp. too low	Limit, to be configured up to -40°C / -40°F or -20°C / -4°F up to +260°C / +500°F or +250°C / +482°F
Conductivity too high	Limit, to be configured by user from 0 up to 500S
Conductivity too low	Limit, to be configured by user from 0 up to 500S
TC1	Limit, to be configured by user from 0 up to 10%/°C
TC2	Limit, to be configured by user from 0 up to 10%/°C
USP limit	Non-configurable
USP margin	Margin, to be configured by user from 0 up to 100%
Polarization	Limit, to be configured by user from 0% up to 50%
SA11 internal temp. outside operating limits	The internal temperature is outside the operating limits from -30°C up to +125°C

• Device status

The device status represents activities of the SA11 device such as but not limited to calibration mode, HOLD mode and Sleep mode.

Note: When SA11 is in sleep mode, all operations which result in output data will be disabled. Communication however remains active.

7.4 Logbook configuration

Logbooks are used to keep an electronic record of events such as error messages and calibrations. By referring to this log, users can, for instance, easily determine maintenance or replacement schedules.

The SA11 Smart Adapter will log events continuously during operation and calibration. Predefined events will be stored in a logbook. These events are distinguished in two types, calibration events and alarm events, each having their own logbook.

Each event contains the following data, each item 4 bytes:

- Date (based upon seconds starting from January 1st, 2000)
- Data
- Event number

For an overview of logbook events see Appendix 7.

Each logbook can store up to 50 events, of which the oldest event will be overwritten by the latest event. A copy of the logbooks is stored too in the ID-chip of the sensor connected. The logbook stored in the ID-chip of the sensor however is leading in case a sensor is replaced or reconnected. At that moment the content of the logbook of the sensor will overwrite the content of the logbooks of the SA11.

Only Yokogawa expert HOST, model FLXA402 and Fieldmate, can read each logbook of the SA11 and if necessary erase each logbook individually.

8 CALIBRATION OF SC (Specific Conductivity)

Calibration should be made to obtain the correct conductivity reading. This reading depends on the cell constant of the sensor and the correct temperature compensation of the process. For both it is important to have a correct temperature reading of the sensor used.

8.1 Temperature calibration

For the accuracy of calibration of SC, it is important to have a precise temperature measurement. Measure the temperature with a high-precision thermometer and adjust the sensor reading (temp. offset) accordingly. For best accuracy, this should be done as near to the normal operating temperature as possible.

8.2 Cell constant calibration

This cell constant is the so-called c.c. adjusted. Normally the cell constant of a conductivity sensor does not change during operation, as long as it remains undamaged, and clean. Therefore, it is vital that in any calibration check, the first step should be to clean the sensor, or at least to check its cleanliness. After cleaning, ensure that the sensor is carefully rinsed in distilled water to remove all traces of the cleaning medium.

Before starting calibration of the cell constant, it is important that the temperature reading of the sensor is correct. If necessary the reading can be adjusted (temp offset) to the correct value.

Calibration has to be done by the HOST system. For cell constant it can be done for manual, automatic or by sample.

Note: The standard instrument to be used in calibration with a process solution must always be accurate. Yokogawa recommends the Model SC82 pocket conductivity meter.

Where temperature compensation is selected and configured for output1 and/or output2, this compensation is effective during calibration. The calculated output is the value converted to a conductivity value at the reference temperature set in Temperature settings (see section 7.1.4).

8.2.1 Cell constant (manual)

The intention of this calibration routine is to fine-tune a sensor for which only the nominal cell constant is known, or to recalibrate a sensor that has been changed (or damaged) during operation.

Choose the 1st or 2nd temperature compensation to suit the calibration solution used. The solution with an appropriate precision should be prepared or purchased. Allow the sensor to reach stable readings for both temperature and conductivity before adjusting to the value of the corresponding calibration solution.

8.2.2 Cell constant (automatic)

This routine is built around the test method described in International Recommendation No. 56 of OIML (Organisation Internationale de Metrologie Legale). The new cell constant is obtained by inserting the sensor in a known solution (see Appendix 5) and measuring the SC value. Selection of the correct solution can be done by the HOST system, see section 7.1.9.

Allow the sensor to reach stable readings for both temperature and conductivity.

8.2.3 Sample

With the sensor in situ, a sample can be taken for laboratory analysis. Sample calibration records the time and reading, and holds these in memory until the analysis has been completed. The laboratory data can then be entered in SA11 device by HOST regardless of the current process value, without the need for calculations.

When sample calibration is made with temperature compensation activated, the types of temperature compensation for laboratory analysis equipment should be matched. Use of a different type of temperature compensation between equipment causes an error. The standard conductivity meter to be used should always be based on the accurate and same temperature compensation calculation method.

8.3 Temperature coefficient (TC)

For a correct conductivity reading in case temperature compensation method is TC, the temperature coefficient can be corrected. Simply put the sensor in the process and allow the sensor to reach stable readings for both temperature and conductivity. The HOST system will show the calculated conductivity value at T_{ref} , and if not the same as the theoretical value the user only has to input this value when requested. The SA11 device will calculate the new TC value.

Note: Before calibrating the temperature coefficient it is important to first calibrate the cell constant.

9 MAINTENANCE

Each device requires (little) periodic maintenance to ensure good performance.

9.1 Periodic maintenance SA11

The SA11 Smart Adapter requires very little periodic maintenance. Keep the contacts of the connectors clean from dust and direct contact with human hand. Especially pH measurement makes use of high impedance sensors and may otherwise be prone to problems. Please use the dust caps in case the SA11 is not used.

Make sure that the connectors are correctly fitted when the device is (re-)installed in order to maintain the weatherproof integrity against water and water vapor.

CAUTION

Do not use an abrasive or organic solvent in cleaning the device.

9.2 Periodic maintenance of sensors

Please follow the user manual of each sensor for the maintenance procedures. The SA11 has a unique prediction function, the so-called wellness check. See for example section 3.4.5. for an explanation of pH.

10 TROUBLESHOOTING

The SA11 contains error diagnostics as explained in Section 4.3.

Flagging of errors, measurement warnings and statuses is done by the SA11 and it depends on the HOST system if flagging and detailed information is indicated. If so, refer to the HOST belonging User's Manual for details. In case of (critical) device errors, at first please check the following items:

10.1 Installation of SA11

- In case of pH, check if the correct SA11 adapter is used with the installed analogue sensor. If not, replace the SA11 adapter by a correct one.
- Check if a Yokogawa sensor with an internal ID-chip is used. If not, replace sensor by the correct type.
- Check if the analogue input of the SA11 is connected in a proper way. The Variopin connectors have to be correctly positioned and firmly screwed, and no moisture must be encapsulated which can reduce the isolation in between the individual contacts. When using the extension cable, check if the correct type is used (see Section 2.2.2)
- Check if wiring to the HOST system is done correctly. The M9 connector has to be screwed firmly and the correct type of interconnection cable must be used (see Section 3.3).
- Check the grounding of the system (see Section 2.3.4).
- Be sure that a sensor is connected to the SA11 before powering the system. If not, the SA11 configuration can be wrong resulting in device errors. By connecting the sensor these error will disappear.

10.2 Setting of the SA11

- Check if the measurement setup is done in a proper way (see Section 3 or Section 6)
 - Check if the commissioning is done in a proper way (see Section 4 or Section 7)
- If not correct, please setup the SA11 in a correct way. In worse case scenario, please execute factory defaults.

10.3 Sensor

- Check if a Yokogawa sensor with an internal ID-chip is used. If not, replace sensor by the correct type.
- Check if the sensor used and is calibrated in a correct way. If not, re-calibrate the sensor.
- In case of a temperature error please check if temperature element is broken. If so replace the sensor or set temperature to manual to resume measurements

10.4 Application

- Check if the SA11 and auxiliary equipment are specified for the environmental conditions. If not, YOKOGAWA cannot guarantee proper working of the SA11
 - Check if the SA11 and sensor are specified for the process conditions. If not, YOKOGAWA cannot guarantee proper working of the SA11 and sensor
- If the (critical) error persists, even when all items are checked and found correct, please replace the SA11 device.

NOTE The SA11 device is a non-repairable unit.

10.5 Functional Check

For limited functional check of the SA11, the device can be connected to a specific accessory, simulator model QT11, which is intended as a diagnostic tool and is permitted to be connected only when both are located in a non-hazardous location/area. For details see C.E. Handbook SA11 Smart Adapter.

11 APPENDICES

11.1 Appendix 1: Factory defaults & setting limits pH

The following table shows the details of the factory defaults of the SA11 and their setting limits. Setting can be done by HOST system but some setting limits are restricted by limitation of HOST.

Table A1.1: Factory defaults & setting limits pH

Item	Factory default	Settings limits Unit		Unit
		Lower limit	Upper limit	
Measurement settings				
manual_temp	+25 / +77	-40 / -40	+260 / +500	°C / °F
temp_ref	+25 / +77	-40 / -40	+260 / +500	°C / °F
temp_offset	0	-10 / +14	+10 / +50	°C / °F
external_temp	NaN	-40 / -40	+260 / +500	°C / °F
pH_temp_coef	0	-0.1	+0.1	pH/°C or pH/°F
ORP1_temp_coef	0	-10	+10	mV/°C or mV/°F
ORP2_temp_coef	0	-10	+10	
pH_grab_offset	0	-300	+300	mV
pH_zero	0	-600	+600	mV
pH_slope	+100	+70	+110	%
pH_ITP	+7	0	+14	pH
pH_zero2	NaN	-600	+600	mV
pH_slope2	NaN	+70	+110	%
ORP1_grab_offset	0	-500	+500	mV
ORP1_zero	0	-500	+500	mV
ORP1_slope	+100	+70	+110	%
ORP2_grab_offset	0	-500	+500	mV
ORP2_zero	0	-500	+500	mV
ORP2_slope	+100	+70	+110	%
Measurement Warning limits				
temp_warning_high_limit	+260 / +500	-40 / -40	+260 / +500	°C / °F
temp_warning_low_limit	-40 / -40	-40 / -40	+260 / +500	°C / °F
pH_warning_high_limit (note)	+16	-2	+16	pH
pH_warning_low_limit (note)	-2	-2	+16	pH
ORP_warning_high_limit	+1500	-1500	+1500	mV
ORP_warning_low_limit	-1500	-1500	+1500	mV
rH_warning_high_limit	100	0	100	
rH_warning_low_limit	0	0	100	
Imp_pHORP_low_warning_high_limit	200	1	+1000	kΩ
Imp_pHORP_low_warning_low_limit	1	1	+1000	kΩ
Imp_ref_low_warning_high_limit	200	1	+1000	kΩ
Imp_ref_low_warning_low_limit	1	1	+1000	kΩ

Item	Factory default	Settings limits Unit		Unit
		Lower limit	Upper limit	
Calibration limits				
zero_high_limit	+120	0	+600	mV
zero_low_limit	+120	-600	0	mV
slope_high_limit	+110	+100	+110	%
slope_low_limit	+70	+70	+110	%
ORP_zero_high_limit	+120	0	+500	mV
ORP_zero_low_limit	-120	-500	0	mV
ORP_slope_high_limit	+110	+100	+110	%
ORP_slope_low_limit	+70	+70	+100	%
Calibration settings				
stabilization_time	5	2	30	seconds
pH_step_range	+0.03	+0.01	+1.0	pH
ORP_step_range	+1	+1	+100	mV
rH_step_range	0.05	0.01	10.00	
calibration_interval	250	1	250	days
buffer_acceptance_range	1.000	0.001	5.000	pH
Communication settings				
Modbus_address	1	1	247	
Serial_profile	1	1	2	
Diagnostics settings				
diag_imp_pHORP_fine	10	1	10	MΩ
diag_imp_ref_fine	10	1	10	MΩ
diag_progress_time_bad_limit	2000	1	10000	days
diag_heat_cycle_bad_limit	500	10	1000	cycles
diag_heat_cycle_temp	+50 / +122	+1 / +33.8	+250 / +482	°C / °F
diag_heat_cycle_time	10	0.1	60	minutes
sterilized_temp	+140 / +284	0 / +32	+140 / +284	°C / °F
sterilized_time	100	0	100	minutes
high_temp1	+140 / +284	-30 / -22	+140 / +284	°C / °F
high_temp2	+140 / +284	-30 / -22	+140 / +284	°C / °F
low_temp	-30 / -22	-30 / -22	+140 / +284	°C / °F
high_pH_value	+13	-2	+16	pH
low_pH_value	+1	-2	+16	pH

NaN: Not a Number

11.2 Appendix 2: Buffer tables and matrix compensation pH

The following table shows the details of the buffer solutions selectable in Calibration settings (see section 4.1.9). Setting can be done by HOST system, unit is pH.

- Buffer tables

Table A2.1: NIST (IEC 60746-2) / DIN 19266

T [°C]	0	5	10	15	20	25	30	35	38	40	45	50	55	60	70	80	90	95
1.68 pH		1.668	1.670	1.672	1.675	1.679	1.683	1.688	1.691	1.694	1.700	1.707	1.715	1.723	1.743	1.766	1.792	1.806
4.01 pH	4.003	3.999	3.998	3.999	4.002	4.008	4.015	4.024	4.030	4.035	4.047	4.060	4.074	4.091	4.126	4.164	4.205	4.227
6.87 pH	6.984	6.951	6.923	6.900	6.881	6.865	6.853	6.844	6.840	6.838	6.834	6.833	6.834	6.836	6.845	6.859	6.877	6.886
9.18 pH	9.464	9.395	9.332	9.276	9.225	9.180	9.139	9.102	9.081	9.068	9.038	9.011	8.985	8.962	8.921	8.885	8.850	8.833

Table A2.2: DIN 19267 (German buffers) so called: technical buffer solutions

T [°C]	0	10	20	25	30	40	50	60	70	80	90
4.65 pH DIN	4.670	4.660	4.650	4.650	4.650	4.660	4.680	4.700	4.720	4.750	4.790
6.79 pH DIN	6.890	6.840	6.800	6.790	6.780	6.760	6.760	6.760	6.760	6.780	6.800
9.23 pH DIN	9.480	9.370	9.270	9.230	9.180	9.090	9.000	8.920	8.880	8.850	8.820

Table A2.3: US technical buffers

T [°C]	0	5	10	15	20	25	30	35	40	45	50	55	60
4.0 pH US	4.000	3.998	3.997	3.998	4.001	4.005	4.001	4.018	4.027	4.038	4.050	4.064	4.080
7.0 pH US	7.120	7.090	7.060	7.040	7.020	7.000	6.990	6.980	6.988	6.978	6.970	6.890	6.980
10.0 pH US	10.317	10.245	10.179	10.118	10.062	10.012	9.966	9.926	9.889	9.856	9.828	9.828	

Table A2.4: Free Programmable buffer 1

T [°C]	0	5	10	15	20	25	30	35	40	45	50	55	60	65	70	75	80
Buffer 4	3.973	3.980	3.990	3.990	4.000	4.010	4.010	4.020	4.040	4.060	4.080	4.080	4.090	4.100	4.100	4.120	4.120

Table A2.5: Free Programmable buffer 2

T [°C]	0	5	10	15	20	25	30	35	40	45	50	55	60	65	70	75	80
Buffer 7	6.907	6.930	6.960	6.980	7.000	7.010	7.020	7.030	7.040	7.050	7.060	7.070	7.080	7.090	7.100	7.110	7.120

Table A2.5: Free Programmable buffer 3

T [°C]	0	5	10	15	20	25	30	35	40	45	50	55	60	65	70	75	80
Buffer 9	9.480	9.350	9.220	9.130	9.000	8.900	8.570	8.460	8.400	8.250	8.280	8.170	8.090	8.030	7.900	7.720	7.580

The freely programmable tables are pre-filled with a basic set of data. This data is based upon pH sodium buffers for differential type pH sensors. These tables however are intended for programming of user preferred buffer solutions. The data concerning the pH temperature characteristic will need to be obtained from the supplier of the buffers.

NOTE Yokogawa recommend the use of NIST (primary buffer standards) rather than buffers which have been adjusted by the addition of acid or alkaline materials to the buffer composition. In this way the customer gets a recognized standard, as well as the best buffer capacity (the ability to resist pH change with contamination).

- Matrix temperature compensation

Table A.2.7 shows the defaults for the matrix temperature compensation selectable in Temperature compensation (see section 4.1.4). Setting can be done by HOST system.

Table A2.7: Defaults for the matrix temp. compensation (Tref.= 25.0°C)

		Minimum --> Maximum					
		T [°C]	Solution 1 [pH]	Solution 2 [pH]	Solution 3 [pH]	Solution 4 [pH]	Solution 5 [pH]
Minimum	Tref	25.0	6.40	7.00	7.30	7.60	9.00
	T1	5.0	6.42	7.38	7.94	8.31	9.74
	T2	25.0	6.40	7.00	7.30	7.60	9.00
	T3	45.0	6.34	6.70	6.86	7.06	8.40
	T4	65.0	6.23	6.45	6.54	6.67	7.91
Maximum	T5	85.0	6.11	6.25	6.31	6.40	7.51

The reference temperature (Tref) is set in the Temperature Compensation, default 25°C. Entering of values needs to be done in the HOST system.

11.3 Appendix 3: Logbook pH

The following table A3.1 shows the stored logbook events for pH. Each event will be logged in case of alarm ON and alarm OFF with time stamp.

Table A3.1: Logbook event list pH

Event name
NVM error
User data CRC error
Factory data CRC error
SA11 not working
temp too high
temp too low
Temp_raw too high
Temp_raw too low
calibration due
Sensor connected to SSA or powered on
ID-chip sync failure
SSA temp out. Design spec
SSA temp out. Operating spec
SENSOR (+ID) detect; when NO ID CHIP Only possible when sensor without ID is connected to SSA
Temperature element not detected
pH too high
pH too low
pH temp comp warning
ORP too high
ORP too low
rH too high
rH too low
IMP1 (low) too high
IMP1 (low) too low
IMP2 (low) too high
IMP2 (low) too low
pH_uncomp_too high
pH_uncomp_pH too low
ORP1_uncomp_too high

ORP1_uncomp_too low
ORP2_uncomp_too high
ORP2_uncomp_too low
LE detect
IMP1 glassbreak detect
IMP2 glassbreak detect

The following table A3.2 shows the logbook for calibration of pH. Each item will be logged with calibration data and time stamp.

Table A3.2: Logbook calibration pH

Item
Temp offset
pH ZERO
pH SLOPE
pH ZERO2
pH SLOPE2
ITP
IMP2 after CAL
ORP ZERO
ORP SLOPE
ORP ZERO2
ORP SLOPE2
pH grab offset
ORP1 grab offset
ORP2 grab offset

11.4 Appendix 4: Factory defaults & setting limits SC

The following table shows the details of the factory defaults of the SA11 and their setting limits. Setting can be done by HOST system but some setting limits are restricted by limitation of HOST.

Table A4.1: Factory defaults & setting limits SC

Item	Factory default	Settings limits Unit		Unit
		Lower limit	Upper limit	
Measurement settings				
manual_temp	+25 / +77	-40 / -40	+260 / +500	°C / °F
temp_ref	+25 / +77	-40 / -40	+260 / +500	°C / °F
temp_offset	0 / +32	-10 / +14	+10 / +50	°C / °F
external_temp	NaN	-40 / -40	+260 / +500	°C / °F
temp_coef1	2.1	0	+10	%/°C
temp_coef1	2.1	0	+10	%/°C
cell_constant_factory	0.1	0.005	50	cm-1
USP_safety_margin	0	0	+100	%
Measurement Warning limits				
temp_warning_high_limit	+260 / +500	-40 / -40	+260 / +500	°C / °F
temp_warning_low_limit	-40 / -40	-40 / -40	+260 / +500	°C / °F
conductance_warning_high_limit	0.25	0	500	S
conductance_warning_low_limit	1	0	500	S
resistance_warning_high_limit	2000000	0	100000000	Ω
resistance_warning_low_limit	0.2	0	100000000	Ω
polarization_high_limit	15	0	50	%
Calibration limits				
c.c._high_limit	120	100	120	%
c.c._low_limit	80	80	120	%
Calibration settings				
stabilization_time	5	2	30	seconds
step_range	1	0.1	20	%
calibration_interval	250	1	250	days
Communication settings				
Modbus_address	1	1	247	
Serial_profile	1	1	2	
Diagnostics settings				
diag_progress_time_bad_limit	2000	1	10000	days
diag_heat_cycle_bad_limit	500	10	1000	cycles
diag_heat_cycle_temp	+50 / +122	+1 / +33.8	+250 / +482	°C / °F
diag_heat_cycle_time	10	0.1	60	minutes
sterilized_temp	+250/ +482	0 / +32	+250/ +482	°C / °F
sterilized_time	100	0	100	minutes
high_temp1	+250/ +482	-20 / -4	+250/ +482	°C / °F
high_temp2	+250/ +482	-20 / -4	+250/ +482	°C / °F
low_temp	-20 / -4	-20 / -4	+250/ +482	°C / °F

NaN: Not a Number

11.5 Appendix 5: Matrix tables and buffer solutions SC

• Matrix tables

		1. NH3 0..50ppb									
		Unit: uS/cm									
		solut. min	solut.2	solut.3	solut.4	solut.5	solut.6	solut.7	solut.8	solut.9	solut. max
		0 ppb	1 ppb	2 ppb	3 ppb	5 ppb	7 ppb	10 ppb	20 ppb	30 ppb	50 ppb
Tmin	0 °C	0.0107	0.0173	0.0229	0.0320	0.0502	0.0688	0.0966	0.1780	0.2590	0.4230
2.	10 °C	0.0226	0.0284	0.0337	0.0442	0.0651	0.0879	0.1220	0.2250	0.3280	0.5350
3.	20 °C	0.0420	0.0466	0.0512	0.0622	0.0842	0.1110	0.1500	0.2740	0.3980	0.6480
4.	30 °C	0.0720	0.0749	0.0788	0.0895	0.1110	0.1390	0.1810	0.3250	0.4690	0.7580
5.	40 °C	0.1150	0.1170	0.1200	0.1300	0.1490	0.1780	0.2210	0.3820	0.5430	0.8660
6.	50 °C	0.1740	0.1760	0.1780	0.1860	0.2030	0.2310	0.2730	0.4480	0.6230	0.9740
7.	60 °C	0.2520	0.2540	0.2560	0.2630	0.2780	0.3040	0.3440	0.5310	0.7180	1.0900
8.	70 °C	0.3490	0.3530	0.3560	0.3630	0.3770	0.4020	0.4390	0.6370	0.8350	1.2300
9.	80 °C	0.4670	0.4750	0.4790	0.4860	0.5010	0.5260	0.5630	0.7700	0.9770	1.3900
Tmax.	90 °C	0.6060	0.6170	0.6230	0.6310	0.6470	0.6710	0.7070	0.9230	1.1400	1.5700
Tref	25 °C	0.0554	0.0608	0.0650	0.0759	0.0976	0.1250	0.1660	0.3000	0.4340	0.7030

		2. Morpholine 0..500ppb									
		Unit: uS/cm									
		solut. min	solut.2	solut.3	solut.4	solut.5	solut.6	solut.7	solut.8	solut.9	solut. max
		0 ppb	10 ppb	20 ppb	30 ppb	50 ppb	70 ppb	100 ppb	200 ppb	300 ppb	500 ppb
Tmin	0 °C	0.0107	0.0252	0.0272	0.0370	0.0565	0.0724	0.0963	0.1440	0.1920	0.2880
2.	10 °C	0.0226	0.0316	0.0402	0.0537	0.0807	0.1040	0.1390	0.2120	0.2850	0.4310
3.	20 °C	0.0420	0.0502	0.0585	0.0749	0.1080	0.1390	0.1850	0.2870	0.3890	0.5920
4.	30 °C	0.0720	0.0781	0.0851	0.1030	0.1400	0.1780	0.2350	0.3670	0.4990	0.7630
5.	40 °C	0.1150	0.1190	0.1240	0.1430	0.1810	0.2240	0.2890	0.4520	0.6140	0.9380
6.	50 °C	0.1740	0.1770	0.1810	0.1990	0.2340	0.2810	0.3510	0.5440	0.7360	1.1200
7.	60 °C	0.2520	0.2540	0.2570	0.2730	0.3060	0.3540	0.4270	0.6480	0.8690	1.3100
8.	70 °C	0.3490	0.3540	0.3570	0.3720	0.4030	0.4520	0.5260	0.7730	1.0200	1.5200
9.	80 °C	0.4670	0.4760	0.4810	0.4970	0.5280	0.5780	0.6540	0.9320	1.2200	1.7700
Tmax.	90 °C	0.6060	0.6190	0.6260	0.6420	0.6740	0.7240	0.7980	1.1000	1.4100	2.0300
Tref	25 °C	0.0554	0.0642	0.0718	0.0890	0.1240	0.1590	0.2100	0.3270	0.4440	0.6780

		3. NH3 15..30%									
		Unit: mS/cm									
		solut. min	solut.2	solut.3	solut.4	solut.5	solut.6	solut.7	solut.8	solut.9	solut. max
		15 %	16 %	18 %	19 %	20 %	22 %	24 %	26 %	28 %	30 %
Tmin	10 °C	0.480	0.430	0.355	0.320	0.295	0.250	0.215	0.185	0.155	0.130
2.	15 °C	0.580	0.530	0.440	0.400	0.370	0.315	0.265	0.235	0.205	0.170
3.	18 °C	0.649	0.599	0.506	0.466	0.433	0.372	0.316	0.277	0.238	0.197
4.	20 °C	0.695	0.645	0.550	0.510	0.475	0.410	0.350	0.305	0.260	0.215
5.	25 °C	0.820	0.770	0.650	0.605	0.563	0.485	0.418	0.363	0.308	0.254
6.	30 °C	0.930	0.870	0.755	0.700	0.650	0.560	0.485	0.420	0.355	0.292
7.	35 °C	1.036	0.970	0.843	0.780	0.733	0.638	0.553	0.477	0.403	0.331
8.	40 °C	1.142	1.070	0.930	0.860	0.815	0.715	0.620	0.533	0.450	0.370
9.	45 °C	1.246	1.164	1.015	0.945	0.890	0.783	0.675	0.581	0.490	0.402
Tmax.	50 °C	1.350	1.258	1.100	1.030	0.965	0.850	0.730	0.628	0.530	0.433
Tref	25 °C	0.820	0.770	0.650	0.605	0.563	0.485	0.418	0.363	0.308	0.254

4. H2SO4 1.5%

Unit: S/cm

		solut. min	solut.2	solut.3	solut.4	solut.5	solut.6	solut.7	solut.8	solut.9	solut. max
		0.5 %	1 %	1.5 %	2 %	2.5 %	3 %	3.5 %	4 %	4.5 %	5 %
Tmin	-1.11 °C	0.0137	0.0304	0.0467	0.0627	0.0780	0.0930	0.1079	0.1224	0.1364	0.1496
2.	10.0 °C	0.0192	0.0385	0.0574	0.0760	0.0943	0.1126	0.1304	0.1480	0.1651	0.1818
3.	21.1 °C	0.0224	0.0446	0.0664	0.0880	0.1093	0.1305	0.1512	0.1715	0.1912	0.2102
4.	32.2 °C	0.0250	0.0498	0.0742	0.0983	0.1222	0.1458	0.1690	0.1917	0.2138	0.2351
5.	43.3 °C	0.0273	0.0543	0.0808	0.1070	0.1331	0.1590	0.1845	0.2095	0.2337	0.2574
6.	54.4 °C	0.0288	0.0580	0.0864	0.1147	0.1428	0.1706	0.1981	0.2247	0.2507	0.2763
7.	60.0 °C	0.0295	0.0596	0.0891	0.1182	0.1470	0.1758	0.2040	0.2317	0.2587	0.2853
8.	71.1 °C	0.0308	0.0622	0.0932	0.1243	0.1550	0.1855	0.2155	0.2444	0.2727	0.3007
9.	87.8 °C	0.0327	0.0658	0.0993	0.1322	0.1650	0.1977	0.2297	0.2612	0.2917	0.3217
Tmax.	98.9 °C	0.0340	0.0682	0.1027	0.1372	0.1713	0.2050	0.2380	0.2708	0.3028	0.3335
Tref	25.0 °C	0.0230	0.0457	0.0689	0.0907	0.1127	0.1352	0.1565	0.1777	0.2005	0.2220

5. H2SO4 0.27%

Unit: S/cm

		solut. min	solut.2	solut.3	solut.4	solut.5	solut.6	solut.7	solut.8	solut.9	solut. max
		0 %	5 %	8 %	12 %	14 %	17 %	20 %	22 %	24 %	27 %
Tmin	-1.11°C	0.0000	0.1496	0.2330	0.3275	0.3695	0.4225	0.4640	0.4850	0.5005	0.5140
2.	10.0 °C	0.0000	0.1818	0.2845	0.4030	0.4535	0.5210	0.5725	0.5980	0.6160	0.6340
3.	21.1 °C	0.0000	0.2102	0.3330	0.4740	0.5335	0.6145	0.6805	0.7140	0.7385	0.7625
4.	32.2 °C	0.0000	0.2351	0.3740	0.5360	0.6070	0.7030	0.7810	0.8225	0.8540	0.8860
5.	43.3 °C	0.0000	0.2574	0.4130	0.5945	0.6735	0.7835	0.8755	0.9250	0.9635	1.0045
6.	54.4 °C	0.0000	0.2763	0.4450	0.6455	0.7315	0.8535	0.9600	1.0185	1.0660	1.1180
7.	60.0 °C	0.0000	0.2853	0.4600	0.6670	0.7570	0.8860	0.9980	1.0600	1.1110	1.1695
8.	71.1 °C	0.0000	0.3007	0.4860	0.7070	0.8060	0.9470	1.0710	1.1395	1.1970	1.2640
9.	87.8 °C	0.0000	0.3217	0.5210	0.7605	0.8665	1.0245	1.1630	1.2420	1.3100	1.3940
Tmax.	98.9 °C	0.0000	0.3335	0.5420	0.7885	0.9025	1.0645	1.2155	1.3020	1.3760	1.4690
Tref	25.0 °C	0.0000	0.2220	0.3469	0.4985	0.5657	0.6479	0.7167	0.7490	0.7780	0.8073

6. NaOH 1.5%

Unit: S/cm

		solut. min	solut.2	solut.3	solut.4	solut.5	solut.6	solut.7	solut.8	solut.9	solut. max
		1 %	1.5 %	2 %	2.5 %	3 %	3.33 %	3.67 %	4 %	4.5 %	5 %
Tmin	0.0 °C	0.0350	0.0486	0.0622	0.0746	0.0870	0.0956	0.1044	0.1130	0.1230	0.1330
2.	10.0 °C	0.0420	0.0594	0.0768	0.0929	0.1090	0.1192	0.1298	0.1400	0.1535	0.1670
3.	20.0 °C	0.0487	0.0706	0.0925	0.1113	0.1302	0.1435	0.1573	0.1707	0.1874	0.2040
4.	30.0 °C	0.0560	0.0810	0.1060	0.1295	0.1530	0.1685	0.1845	0.2000	0.2210	0.2420
5.	40.0 °C	0.0630	0.0930	0.1230	0.1510	0.1790	0.1968	0.2152	0.2330	0.2570	0.2810
6.	50.0 °C	0.0700	0.1039	0.1378	0.1694	0.2010	0.2221	0.2439	0.2650	0.2925	0.3200
7.	62.5 °C	0.0840	0.1219	0.1598	0.1931	0.2264	0.2518	0.2781	0.3036	0.3334	0.3631
8.	75.0 °C	0.0961	0.1382	0.1802	0.2172	0.2541	0.2830	0.3128	0.3417	0.3750	0.4083
9.	87.5 °C	0.1090	0.1550	0.2010	0.2410	0.2811	0.3131	0.3461	0.3781	0.4147	0.4513
Tmax.	100.0 °C	0.1190	0.1690	0.2190	0.2670	0.3150	0.3454	0.3766	0.4070	0.4510	0.4950
Tref	25.0 °C	0.0520	0.0766	0.1013	0.1216	0.1420	0.1555	0.1695	0.1830	0.2025	0.2220

7. NaOH 0..15%

Unit: S/cm

		solut. min	solut.2	solut.3	solut.4	solut.5	solut.6	solut.7	solut.8	solut.9	solut. max
		0 %	1 %	3 %	4 %	5 %	6 %	8 %	10 %	12 %	15 %
Tmin	0 °C	0.000	0.035	0.087	0.113	0.133	0.150	0.176	0.195	0.206	0.215
2.	10 °C	0.000	0.042	0.109	0.140	0.167	0.190	0.226	0.255	0.206	0.293
3.	18 °C	0.000	0.047	0.125	0.163	0.195	0.221	0.267	0.303	0.327	0.345
4.	25 °C	0.000	0.052	0.142	0.183	0.222	0.256	0.313	0.355	0.381	0.410
5.	30 °C	0.000	0.056	0.153	0.200	0.242	0.278	0.338	0.389	0.424	0.467
6.	40 °C	0.000	0.063	0.179	0.233	0.281	0.323	0.396	0.458	0.502	0.551
7.	50 °C	0.000	0.070	0.201	0.265	0.320	0.368	0.454	0.527	0.580	0.645
8.	60 °C	0.000	0.080	0.223	0.293	0.355	0.410	0.507	0.592	0.658	0.742
9.	80 °C	0.000	0.100	0.270	0.350	0.425	0.493	0.612	0.721	0.814	0.936
Tmax.	100 °C	0.000	0.119	0.315	0.407	0.495	0.574	0.717	0.850	0.967	1.130
Tref	25 °C	0.000	0.052	0.142	0.183	0.222	0.256	0.313	0.355	0.381	0.410

8. HCl 0..200ppb

Unit: uS/cm

		solut. min	solut.2	solut.3	solut.4	solut.5	solut.6	solut.7	solut.8	solut.9	solut. max
		0 ppb	1 ppb	2 ppb	4 ppb	10 ppb	20 ppb	50 ppb	100 ppb	150 ppb	200 ppb
Tmin	0 °C	0.0107	0.0135	0.0161	0.0228	0.0472	0.0912	0.2256	0.4504	0.6755	0.9005
2.	10 °C	0.0226	0.0253	0.0281	0.0352	0.0630	0.1163	0.2834	0.5645	0.8462	1.1280
3.	20 °C	0.0420	0.0446	0.0476	0.0550	0.0843	0.1443	0.3407	0.6755	1.0115	1.3479
4.	30 °C	0.0720	0.0743	0.0776	0.0852	0.1149	0.1785	0.3993	0.7837	1.1714	1.5599
5.	40 °C	0.1149	0.1177	0.1212	0.1291	0.1588	0.2234	0.4617	0.8904	1.3261	1.7636
6.	50 °C	0.1744	0.1781	0.1819	0.1901	0.2198	0.2838	0.5316	0.9969	1.4758	1.9584
7.	60 °C	0.2517	0.2586	0.2626	0.2711	0.3009	0.3637	0.6139	1.1058	1.6213	2.1439
8.	70 °C	0.3492	0.3617	0.3658	0.3745	0.4044	0.4657	0.7127	1.2198	1.7638	2.3198
9.	80 °C	0.4670	0.4883	0.4926	0.5015	0.5313	0.5910	0.8312	1.3419	1.9045	2.4858
Tmax.	100 °C	0.7631	0.8094	0.8137	0.8225	0.8515	0.9075	1.1273	1.6153	2.1819	2.7844
Tref	25 °C	0.0554	0.0579	0.0611	0.0686	0.0982	0.1604	0.3697	0.7299	1.0921	1.4549

9. HCl 0..5%

Unit: S/cm

		solut. min	solut.2	solut.3	solut.4	solut.5	solut.6	solut.7	solut.8	solut.9	solut. max
		0.365%	1.000%	1.820%	2.500%	3.000%	3.300%	3.650%	4.200%	5.000%	5.470%
Tmin	0 °C	0.02444	0.06331	0.1144	0.1495	0.1760	0.1913	0.2117	0.2350	0.2709	0.2943
2.	5 °C	0.02750	0.07131	0.1274	0.1681	0.1979	0.2151	0.2352	0.2641	0.3042	0.3254
3.	10 °C	0.03045	0.07876	0.1415	0.1857	0.2185	0.2376	0.2616	0.2917	0.3358	0.3623
4.	15 °C	0.03333	0.08597	0.1541	0.2029	0.2387	0.2595	0.2839	0.3185	0.3667	0.3923
5.	25 °C	0.03911	0.1009	0.1804	0.2377	0.2796	0.3039	0.3322	0.3728	0.4292	0.4587
6.	35 °C	0.04468	0.1153	0.2060	0.2715	0.3194	0.3472	0.3794	0.4259	0.4903	0.5241
7.	45 °C	0.05011	0.1291	0.2306	0.3039	0.3576	0.3887	0.4248	0.4770	0.5493	0.5873
8.	50 °C	0.05269	0.1351	0.2412	0.3187	0.3750	0.4076	0.4453	0.5003	0.5760	0.6162
9.	55 °C	0.05528	0.1421	0.2540	0.3348	0.3940	0.4283	0.4681	0.5258	0.6056	0.6476
Tmax.	65 °C	0.06028	0.1545	0.2762	0.3641	0.4285	0.4659	0.5093	0.5721	0.6592	0.7049
Tref	25 °C	0.03911	0.1009	0.1804	0.2377	0.2796	0.3039	0.3322	0.3728	0.4292	0.4587

10. HCl 0..18%

Unit: S/cm

		solut. min	solut.2	solut.3	solut.4	solut.5	solut.6	solut.7	solut.8	solut.9	solut. max
		0.00%	3.65%	5.47%	7.29%	9.12%	10.90%	12.80%	14.60%	16.40%	18.20%
Tmin	-10 °C	0.0000	0.1588	0.2215	0.2760	0.3293	0.3624	0.3896	0.4108	0.4270	0.4390
2.	0 °C	0.0000	0.2117	0.2943	0.3640	0.4213	0.4638	0.4886	0.5168	0.5378	0.5515
3.	10 °C	0.0000	0.2616	0.3623	0.4454	0.5128	0.5655	0.6027	0.6324	0.6543	0.6675
4.	15 °C	0.0000	0.2839	0.3923	0.4814	0.5535	0.6102	0.6528	0.6860	0.7083	0.7220
5.	20 °C	0.0000	0.3122	0.4313	0.5258	0.5995	0.6579	0.7056	0.7424	0.7677	0.7830
6.	25 °C	0.0000	0.3322	0.4587	0.5628	0.6473	0.7128	0.7641	0.8000	0.8240	0.8370
7.	30 °C	0.0000	0.3590	0.4967	0.6066	0.6925	0.7599	0.8152	0.8568	0.8847	0.9010
8.	45 °C	0.0000	0.4248	0.5873	0.7212	0.8300	0.9144	0.9779	1.0260	1.0580	1.0770
9.	55 °C	0.0000	0.4681	0.6476	0.7960	0.9168	1.0110	1.0800	1.1340	1.1710	1.1920
Tmax.	65 °C	0.0000	0.5093	0.7049	0.8672	1.0000	1.1040	1.1800	1.2400	1.2810	1.3050
Tref	25 °C	0.0000	0.3322	0.4587	0.5628	0.6473	0.7128	0.7641	0.8000	0.8240	0.8370

11. HNO3 1..5%

Unit: S/cm

		solut. min	solut.2	solut.3	solut.4	solut.5	solut.6	solut.7	solut.8	solut.9	solut. max
		1.00 %	1.50 %	2.00 %	2.50 %	3.00 %	3.33 %	3.67 %	4.00 %	4.50 %	5.00 %
Tmin	0 °C	0.0395	0.0578	0.0761	0.0948	0.1134	0.1246	0.1360	0.1472	0.1634	0.1795
2.	10 °C	0.0485	0.0704	0.0923	0.1149	0.1374	0.1510	0.1650	0.1786	0.1987	0.2188
3.	15 °C	0.0529	0.0767	0.1004	0.1249	0.1494	0.1642	0.1795	0.1943	0.2163	0.2384
4.	20 °C	0.0574	0.0830	0.1085	0.1350	0.1614	0.1774	0.1940	0.2100	0.2340	0.2580
5.	30 °C	0.0694	0.0989	0.1283	0.1583	0.1882	0.2061	0.2246	0.2425	0.2683	0.2940
6.	40 °C	0.0814	0.1148	0.1481	0.1816	0.2150	0.2348	0.2552	0.2750	0.3025	0.3300
7.	50 °C	0.0907	0.1276	0.1645	0.2010	0.2375	0.2591	0.2814	0.3030	0.3333	0.3635
8.	60 °C	0.0999	0.1404	0.1808	0.2204	0.2600	0.2834	0.3076	0.3310	0.3640	0.3970
9.	70 °C	0.1139	0.1564	0.1989	0.2392	0.2795	0.3036	0.3284	0.3525	0.3875	0.4225
Tmax.	80 °C	0.1278	0.1724	0.2170	0.2580	0.2990	0.3238	0.3493	0.3740	0.4110	0.4480
Tref	25 °C	0.0634	0.0909	0.1184	0.1466	0.1748	0.1918	0.2093	0.2263	0.2511	0.2760

12. HNO3 0..25%

Unit: S/cm

		solut. min	solut.2	solut.3	solut.4	solut.5	solut.6	solut.7	solut.8	solut.9	solut. max
		0.00%	3.12%	6.20%	9.30%	12.40%	15.32%	17.72%	20.11%	22.46%	24.80%
Tmin	0 °C	0.0000	0.1140	0.2259	0.3120	0.3980	0.4472	0.4854	0.5236	0.5498	0.5760
2.	18 °C	0.0000	0.1606	0.3178	0.4345	0.5512	0.6062	0.6559	0.7055	0.7368	0.7680
3.	20 °C	0.0000	0.1650	0.3215	0.4395	0.5575	0.6236	0.6742	0.7248	0.7568	0.7887
4.	25 °C	0.0000	0.1780	0.3490	0.4760	0.6030	0.6655	0.7186	0.7717	0.8119	0.8520
5.	30 °C	0.0000	0.1900	0.3665	0.5002	0.6339	0.7065	0.7619	0.8172	0.8555	0.8938
6.	40 °C	0.0000	0.2110	0.4095	0.5588	0.7081	0.7860	0.8451	0.9042	0.9511	0.9980
7.	50 °C	0.0000	0.2600	0.4507	0.6154	0.7801	0.8620	0.9239	0.9857	1.0440	1.1020
8.	60 °C	0.0000	0.3100	0.4899	0.6699	0.8498	0.9345	0.9982	1.0620	1.1330	1.2050
9.	70 °C	0.0000	0.3330	0.5273	0.7223	0.9173	1.0040	1.0680	1.1320	1.2190	1.3060
Tmax.	80 °C	0.0000	0.3560	0.5660	0.7770	0.9826	1.0690	1.1330	1.1980	1.3020	1.4070
Tref	25 °C	0.0000	0.1780	0.3490	0.4760	0.6030	0.6655	0.7186	0.7717	0.8119	0.8520

• Buffer solutions

The tables are derived from the Standards laid down in “International Recommendation No. 56 of the Organisation Internationale de Métrologie Legale”.

Table A5.1: SC buffer solutions

T [°C]	10	12	14	16	18	20	22	24
1.000M KCl	78,88731	83,00522	87,16523	91,38752	95,70937	100,09892	104,61466	109,12745
0.100M KCl	9,10702	9,58240	10,06265	10,55008	11,04901	11,55576	12,07707	12,59804
0.010M KCl	0,99809	1,05019	1,10282	1,15624	1,21092	1,26646	1,32359	1,38069
0.005M KCl	0,50900	0,53557	0,56241	0,58966	0,61754	0,64586	0,67500	0,70412
0.002M KCl	0,20666	0,21745	0,22835	0,23941	0,25073	0,26223	0,27406	0,28588
0.001M KCl	0,10411	0,10955	0,11504	0,12061	0,12631	0,13210	0,13806	0,14402
T [°C]	25	26	28	30	32	34	35	
1.000M KCl	111,31000	113,69765	118,03818	122,72326	127,50286	132,04033	134,27021	
0.100M KCl	12,85000	13,12564	13,62672	14,16759	14,71936	15,24318	15,50060	
0.010M KCl	1,40830	1,43851	1,49343	1,55270	1,61317	1,67058	1,69879	
0.005M KCl	0,71820	0,73361	0,76161	0,79184	0,82268	0,85196	0,86634	
0.002M KCl	0,29160	0,29785	0,30923	0,32150	0,33402	0,34591	0,35175	
0.001M KCl	0,14690	0,15005	0,15578	0,16196	0,16827	0,17426	0,17720	

11.6 Appendix 6: USP <645>

First published in the USP23 (The United States Pharmacopeia, ed. 23), the USP <645> describes a procedure of measuring the conductivity of Purified Water and WFI (Water for Injection) instead of the previous complicated monitoring procedure. This procedure consists of three stages for measuring the conductivity of Purified Water and WFI.

On the stage 1, firstly the temperature of the water and the non-temperature-compensated conductivity of the water are measured, and this conductivity is compared with the limit conductivity value of the corresponding temperature directed by USP<645>. If the conductivity is higher than the limit value, the procedure will proceed to the stage 2.

The SA11 has the limit values of USP<645> built in the firmware. If activated in the error configuration, the SA11 checks the non-temperature compensated conductivity with the limit value. If the conductivity is higher than the limit value, a USP limit warning will be generated. A safety margin to the limit value can be set to generate a USP margin warning below limit value. When the safety margin is set at 20%, for example, a USP margin warning will be flagged when the non-temperature compensated conductivity goes higher than the 80% of the limit value at all temperatures. For example, if the temperature is 64 °C and the safety margin is set at 20%, then USP warning will be flagged at $0.8 \times 2.2\mu\text{S}/\text{cm} = 1.76\mu\text{S}/\text{cm}$ ($2.2\mu\text{S}/\text{cm}$ is the USP<645> limit value at 64°C). In resistivity mode, a USP warning will be generated at a non-temperature compensated resistivity of $0.568 \text{ M}\Omega$ ($=1/1.76\mu\text{S}/\text{cm}$).

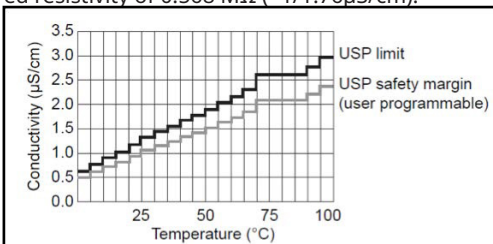

Fig A6.1: Conductivity limit values at process temperatures directed by USP<645>

11.7 Appendix 7: Logbook SC

The following table shows the stored logbook events for SC. Each event will be logged in case of alarm ON and alarm OFF with time stamp.

Table A7.1: Logbook event list SC

Event name
NVM error
User data CRC error
Factory data CRC error
SA11 not working
temp too high
temp too low
Temp_raw too high
Temp_raw too low
calibration due
Sensor connected to SSA or powered on
ID-chip sync failure
SSA temp out. Design spec
SSA temp out. Operating spec
SENSOR (+ID) detect; when NO ID CHIP
Temperature element not detected
SC too high
SC temp comp warning output 1
SC too low
SC temp comp warning output 2
Polarization
USP limit
USP margin
Concentration table
Matrix 2
Matrix 1
Input resistance too high
Input resistance too low

The following table shows the logbook for calibration of SC. Each item will be logged with calibration data and time stamp.

Table A7.2: Logbook calibration SC

Item
Temp offset
SC offset
c.c. factory
c.c. adjusted
TC1
TC2

<p>YOKOGAWA ELECTRIC CORPORATION World Headquarters 9-32, Nakacho 2-chome, Musashino-shi Tokyo 180-8750 Japan www.yokogawa.com</p>	<p>YOKOGAWA ELECTRIC ASIA Pte. LTD. 5 Bedok South Road Singapore 469270 Singapore www.yokogawa.com/sg</p>	<p>Yokogawa has an extensive sales and distribution network. Please refer to the European website (www.yokogawa.com/eu) to contact your nearest representative.</p>
<p>YOKOGAWA CORPORATION OF AMERICA 2 Dart Road Newnan GA 30265 USA www.yokogawa.com/us</p>	<p>YOKOGAWA CHINA CO. LTD. Room 1801, Tower B, THE PLACE No.100 Zunyi Road Changding District, Shanghai, China www.yokogawa.com/cn</p>	
<p>YOKOGAWA EUROPE BV Euroweg 2 3826 HD AMERSFOORT The Netherlands www.yokogawa.com/eu</p>	<p>YOKOGAWA MIDDLE EAST B.S.C.(c) P.O. Box 10070, Manama Building 577, Road 2516, Busaiten 225 Muharraq, Bahrain www.yokogawa.com/bh</p>	

YOKOGAWA 

IM 12A06S01-00EN-P

Printed in The Netherlands, 05-2605

Subject to change without notice

Copyright©

IM12A06S01-00EN-P